

Unpacking the Lift

Your Fully Powered or Universal Inside Lift was factory pre-assembled to require little assembly before installation.

AL420 / AL410

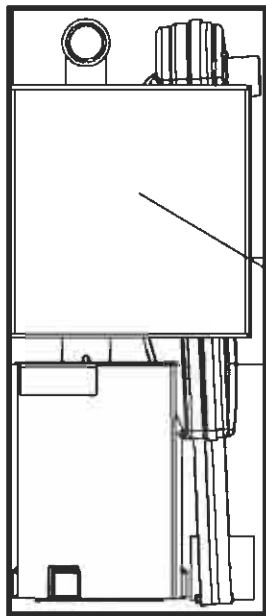

2x
LEG
EXTENSIONS

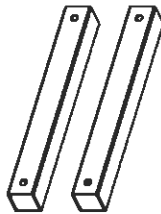

HAND
CONTROLLER

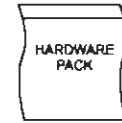

3x



INSTALLATION
WASHERS



VEHICLE
HARNESS

- 2 - 3/8"-16 X 3-1/2" HHCS (fully threaded)
- 1 - 3/8"-16 X 3" HHCS (fully threaded)
- 3 - 3/8"-16 NYLOCS
- 3 - 3/8"-SAE FLAT WASHERS
- 1 - 3/8" FENDER WASHER
- 10 - 15" WIRE TIES
- 1 - 6" STRIP of VELCRO (for hand controller)
- 1 - RUBBER GROMMET (for Vehicle Harness)
- OWNERS MANUAL WITH WARRANTY

AL220 / AL210

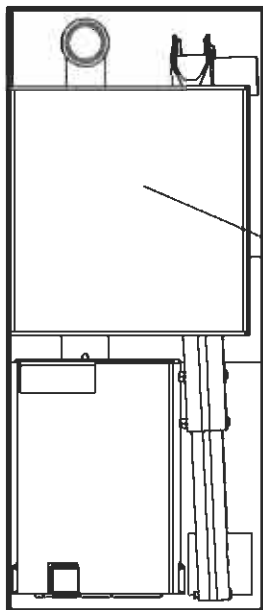

2x
LEG
EXTENSIONS

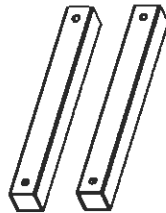

HAND
CONTROLLER

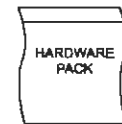

3x



INSTALLATION
WASHERS



VEHICLE
HARNESS

- 2 - 3/8"-16 X 3-1/2" HHCS (fully threaded)
- 1 - 3/8"-16 X 3" HHCS (fully threaded)
- 3 - 3/8"-16 NYLOCS
- 3 - 3/8"-SAE FLAT WASHERS
- 1 - 3/8" FENDER WASHER
- 10 - 15" WIRE TIES
- 1 - 6" STRIP of VELCRO (for hand controller)
- 1 - RUBBER GROMMET (for Vehicle Harness)
- OWNERS MANUAL WITH WARRANTY

Be sure and check the contents of the box against the package check list to be sure that all parts are included with the lift that are required for proper installation. If any parts are missing or if any damage is noted, immediately contact the distributor from which you purchased your lift. DO NOT attempt to install or use the lift with any missing or damaged parts.

Unpacking the Lift

AL800 P/U Truck Lift

Package Check List

- Lifting Arm (# 1)
- Post and Base (# 2)
- Base Legs (#3)

Hardware Package

- Contents include:
- Vehicle Wiring Harness (# 4)
 - Switch Harnesses (#5)
 - Extension Wires (#6)
 - 3 - Installation Washers
 - Required Fasteners
 - Black zip ties

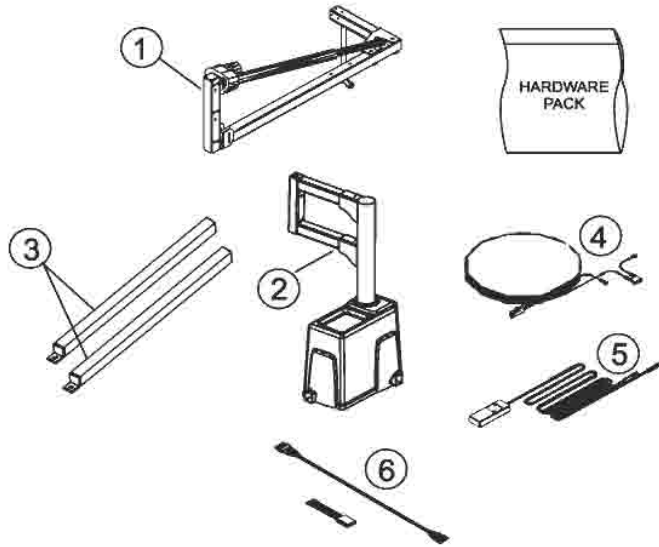

AL055 Economy Lift

Package Check List

- Lifting Arm (# 1)
- Post (# 2)
- Base (# 3)
- Strap (# 4)

Hardware Package

- Contents include:
- Vehicle Wiring Harness (# 5)
 - Switch Harness (# 6)
 - 3 - Installation Washers
 - Required Fasteners
 - Black zip ties

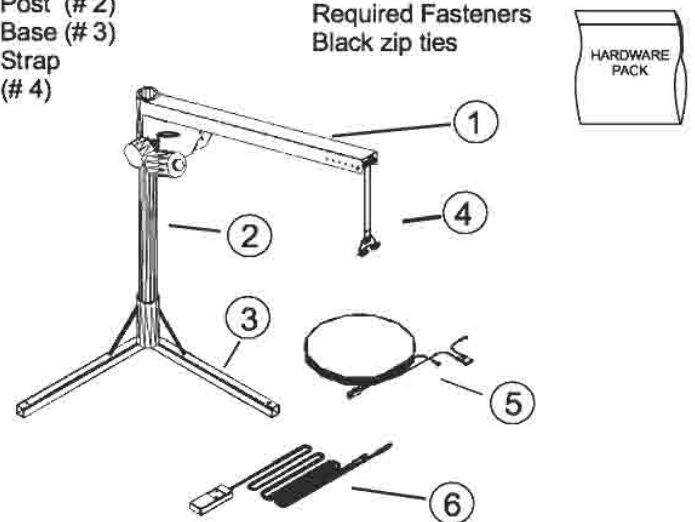

AL400 Fully Powered Lift

Package Check List

- Lifting Arm (# 1)
- Standard Post (# 2)
- Base (# 3)
- Strap Hook Assembly (# 4)
- Leg Extensions (# 5)

Hardware Package

- Contents include:
- Vehicle Wiring Harness (# 6)
 - Hand Control (# 7)
 - 3 - Installation Washers
 - Required Fasteners
 - Black zip ties

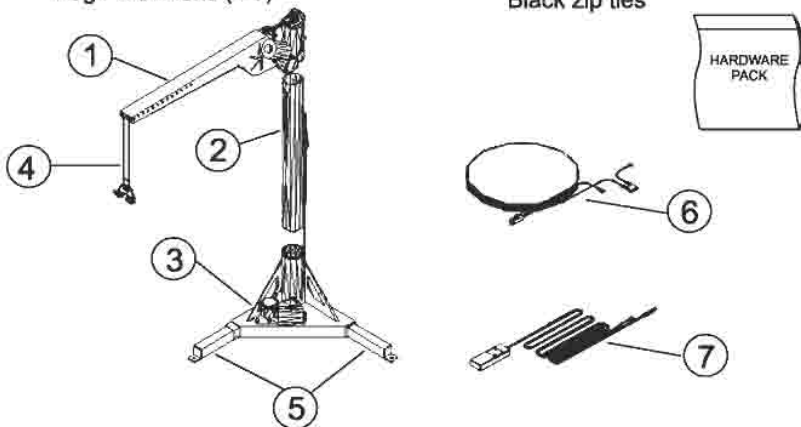

AL200 Universal Inside Lift

Package Check List

- Lifting Arm (# 1)
- Standard Post (# 2)
- Base (# 3)
- Strap Hook Assembly (# 4)
- Leg Extensions (# 5)

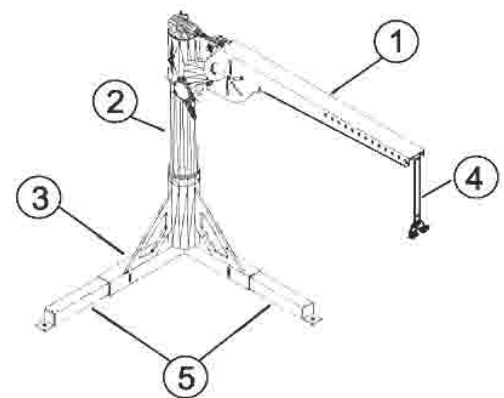

Be sure and check the contents of the box against the package check list to be sure that all parts are included with the lift that are required for proper installation. If any parts are missing or if any damage is noted, immediately contact the distributor from which you purchased your lift. DO NOT attempt to install or use the lift with any missing or damaged parts.

Vehicle Wiring Harness (except AL800)

Installation Instructions

- 1 Unwind the harness and lay it flat. One end of the harness has a black plug . This end of the harness goes to the back of the vehicle.

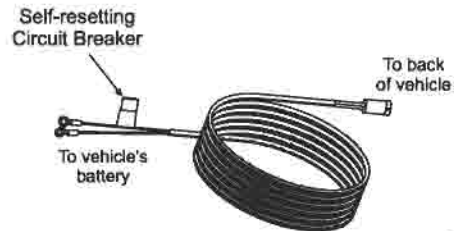

- 2 **BEGIN ROUTING THE VEHICLE HARNESS AT THE BATTERY**
Attach the black wire to the negative terminal on the battery.
Do not attach the red wire yet.

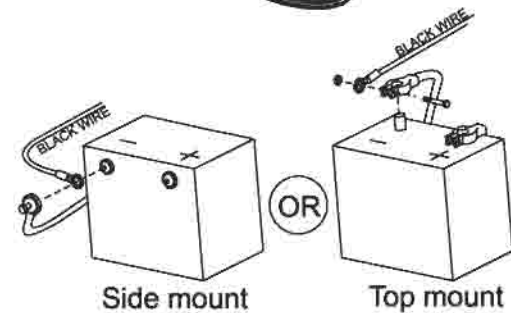

- 3 Run the wiring harness under, or when possible through the vehicle, back to the rear. Always locate the wiring harness where it can not be snagged by road debris and away from the vehicle's gas tank.
If the harness is too long for the vehicle, coil the excess wire and secure it to the vehicle frame with cable ties. **Do not cut or shorten the harness.** Secure the plug where the lift will be installed.

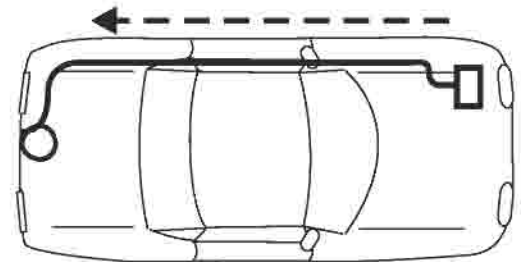

- 4 Attach the red wire to the positive terminal on the battery.

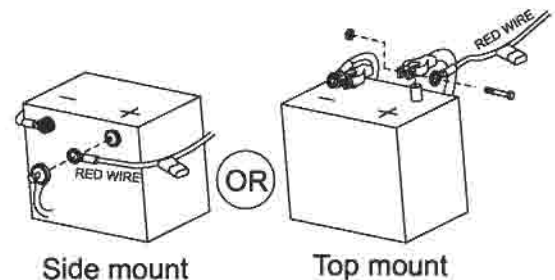

Important Reminder: Never attempt to attach the wire harness to a secondary power source. The harness requires direct connection to the battery.

Caution: Route the harness away from the exhaust system, brake lines, fuel lines, gas tank, pinch points, and sharp edges. Locate the wiring harness where it can not be snagged by road debris.

AL420 / 410 / 220 / 210 Lift Preparation

The Universal Inside Lift has been assembled from the factory for Passenger Side installation.

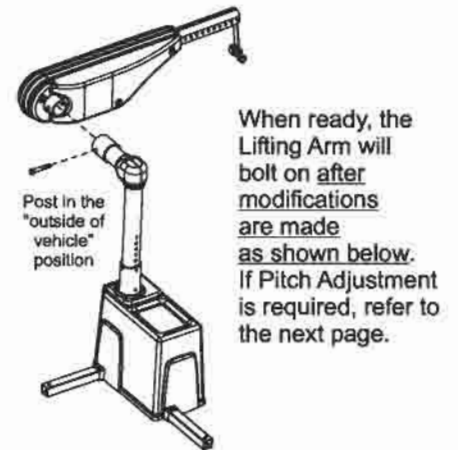
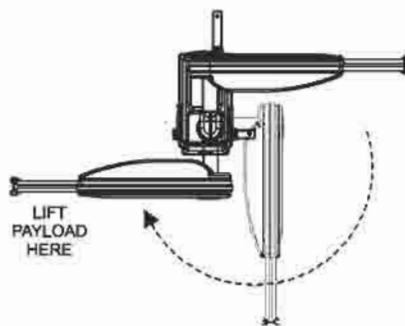
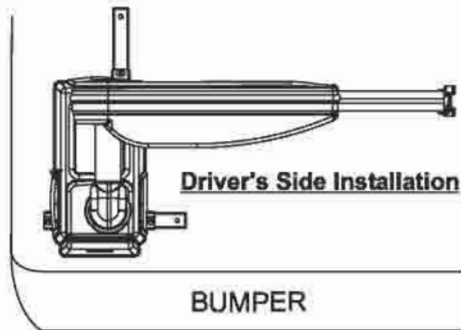
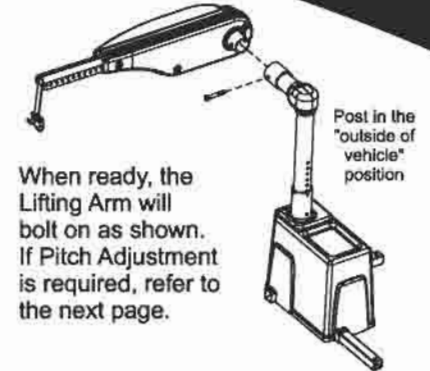
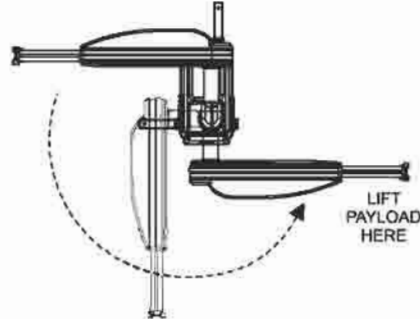
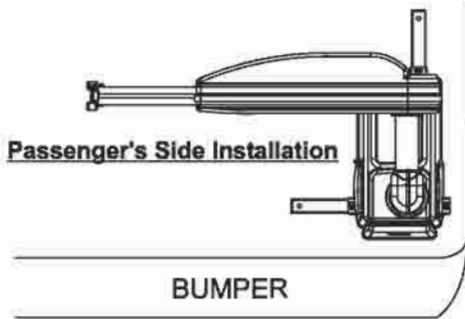

If the application calls for a Driver's Side installation, two of the Lifting Arm's component locations will need to be swapped as shown below.

Swapping Lifting Arm Components For Driver's Side Installation

If Arm Pitch Adjustment is required, please review next page prior to this procedure, as steps can be consolidated.

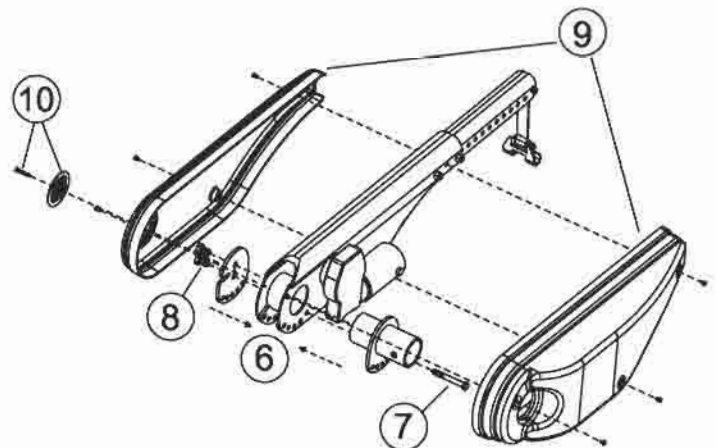
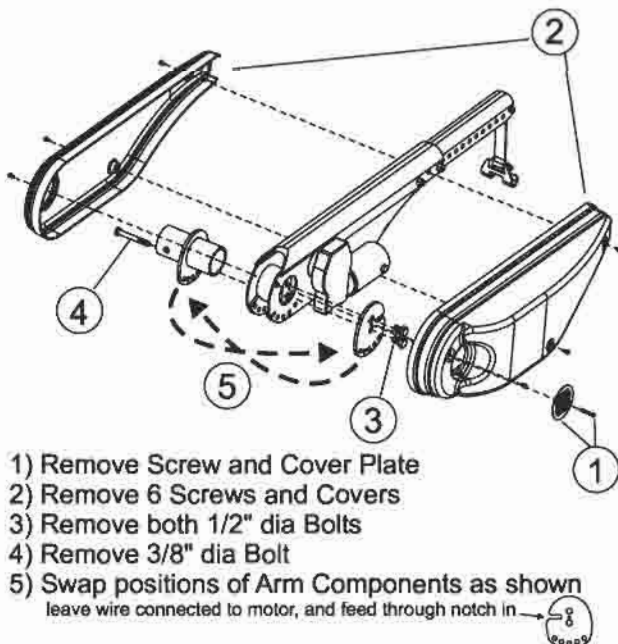

AL420 / 410 / 220 / 210 Lift Preparation

The Inside Lift has been designed with the shortest height and smallest footprint requirements to allow maximum room for the loading and unloading of your scooter or power chair. It is important to familiarize oneself with the available adjustments in order to effectively install the lift, and maintain the maximum available cargo area.

Trial Fit Procedure:

- To obtain the ideal mounting location and avoid possible interference, the lift should be pre-assembled and "trial fit" in the desired installation location. This procedure may require two people, one person to hold the lift in the desired position and another to move the Lifting Arm through its full range of motion. The Inside Lifts have been engineered so it can easily be configured as a solution for most applications. This "trial fit" will also help you determine where the Vehicle Wiring Harness will be run.

Hint: It is always best to check with the customer when determining lift placement and ask permission before drilling through the vehicle's floor.

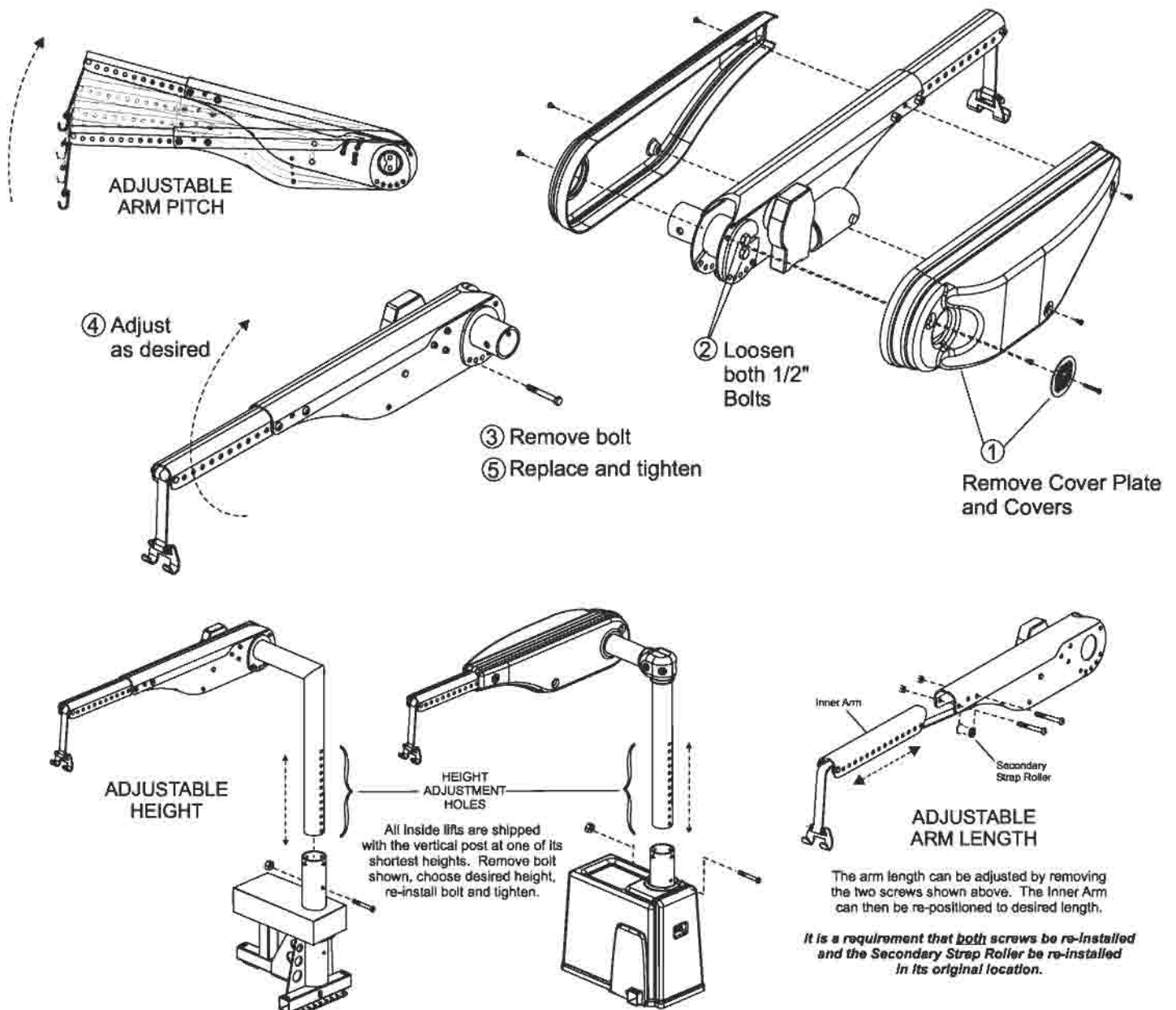

AL420 / 410 / 220 / 210 Lift Preparation

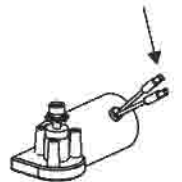
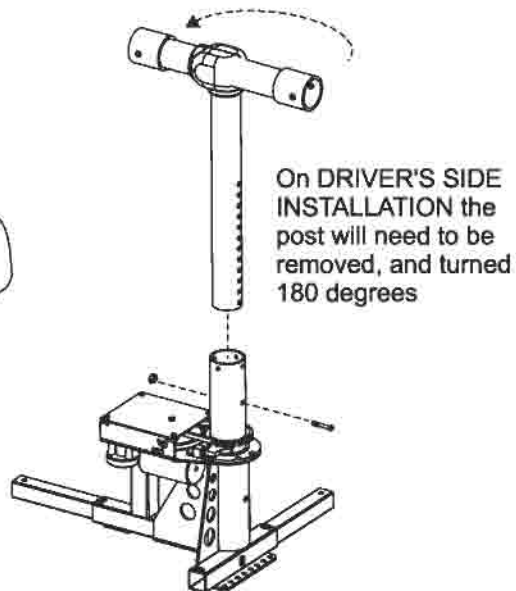
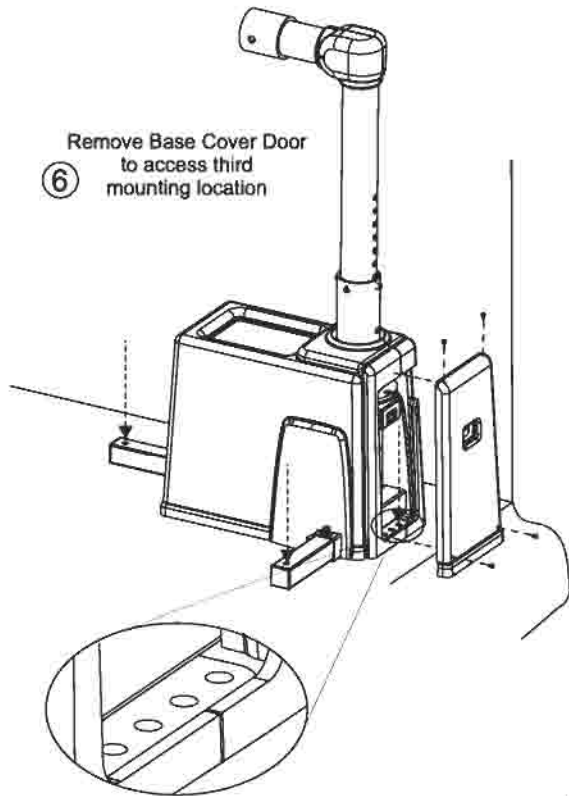
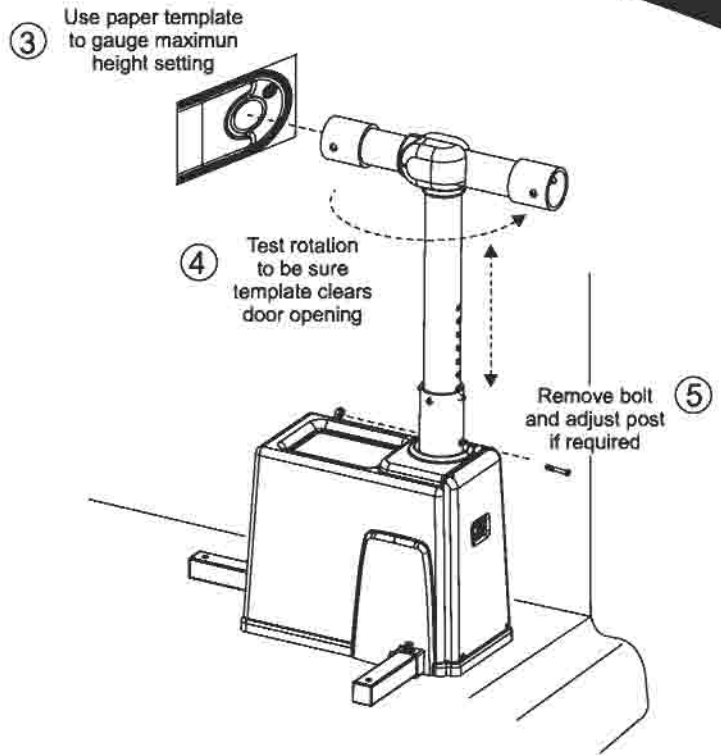
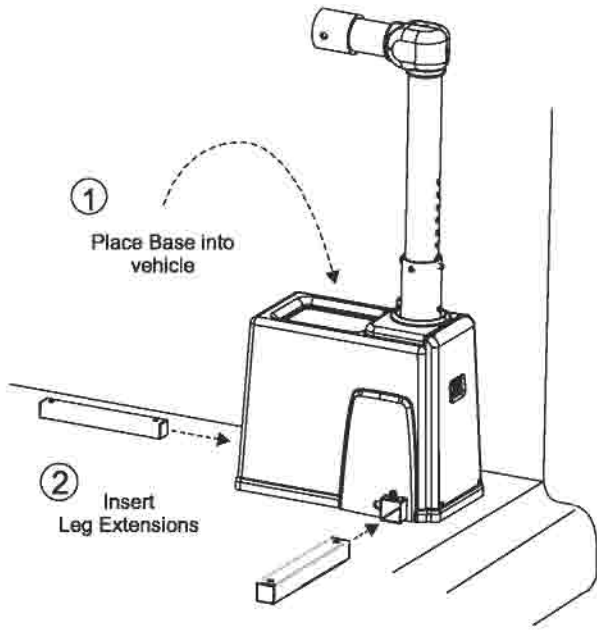

On Power Rotation Models it will also be necessary to switch polarity of the motor to match the direction of the motor to the hand control

Simply swap the wire connections at the rotation motor, located in the base.

AL420 / 410 / 220 / 210 Installation

Once confidence has been gained on the position of the lift mounting, and the "Trial Fit" procedure has been completed, three 3/8" holes will need to be drilled on the marked locations.

Caution! Avoid the vehicle wiring, fuel lines, fuel tanks, spare tires, etc. when drilling

Once holes are drilled, fasten lift to vehicle floor using supplied hardware in the Hardware Pack. Be sure to tighten ALL fasteners including Set Screws.



ALL THREAD KIT MAY BE REQUIRED

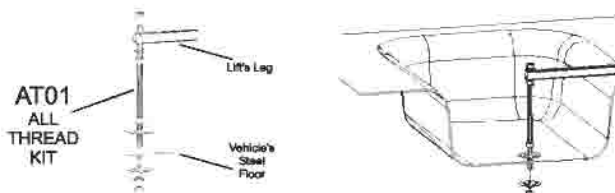

Spare tire storage - Some vehicles store the spare tire under the floor of the vehicle. Make sure that the base can be bolted through to a steel floor or frame.

Some vehicles have storage compartments in the rear cargo area, potentially effecting lift placement. Most of these can be overcome with the aid of an ALL THREAD KIT. Shown above is the typical application for overcoming these storage compartments or wells.

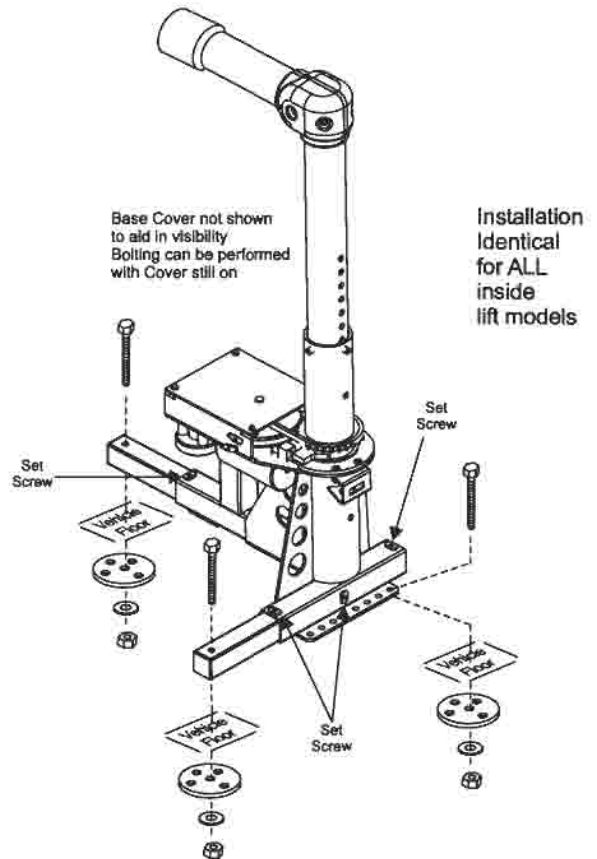

Base Cover not shown to aid in visibility. Bolting can be performed with Cover still on

Installation Identical for ALL inside lift models

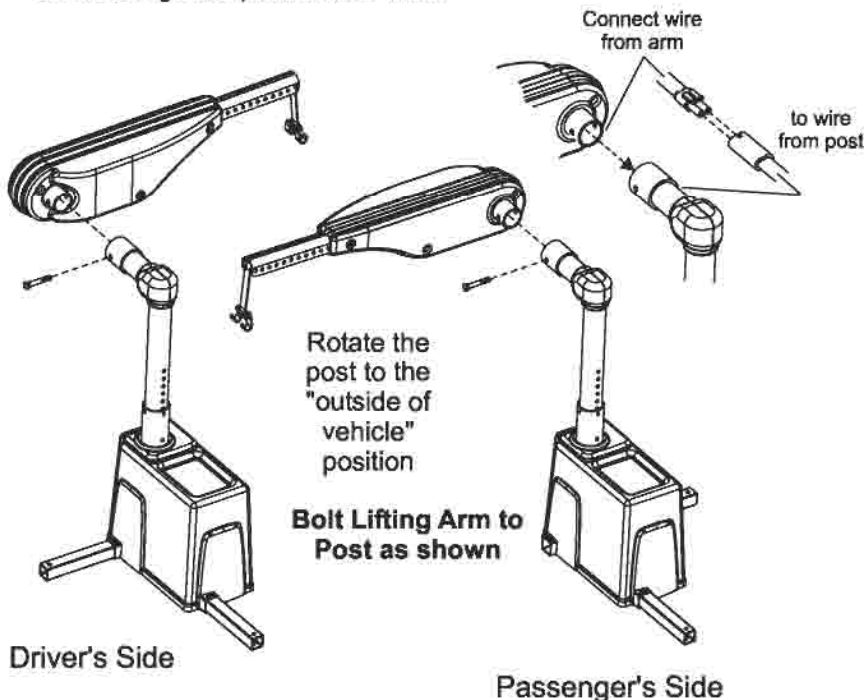

Rotate the post to the "outside of vehicle" position

Bolt Lifting Arm to Post as shown

Connect wire from arm

to wire from post

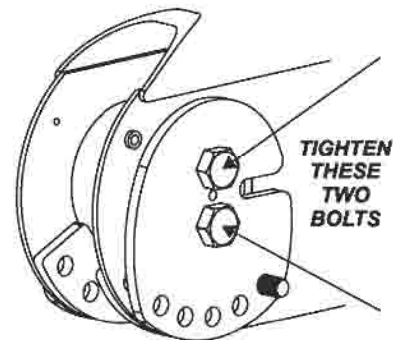

TIGHTEN THESE TWO BOLTS

Once the lift's installation has been completed, and arm pitch is satisfactory, it is crucial these bolts be tightened **BEFORE** any payload lifting is attempted

This can be accomplished even with the cosmetic arm cover on. The arm cover's face plate can be removed with one screw to gain access.

AL420 / 410 / 220 / 210 Installation

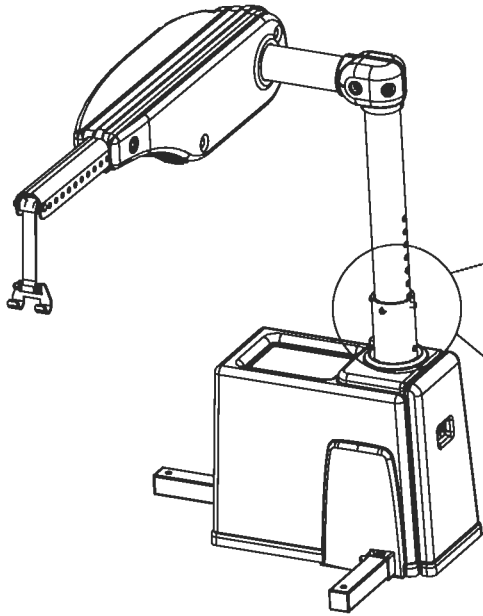

Once proper arm height is determined, tighten the four set screws shown below.

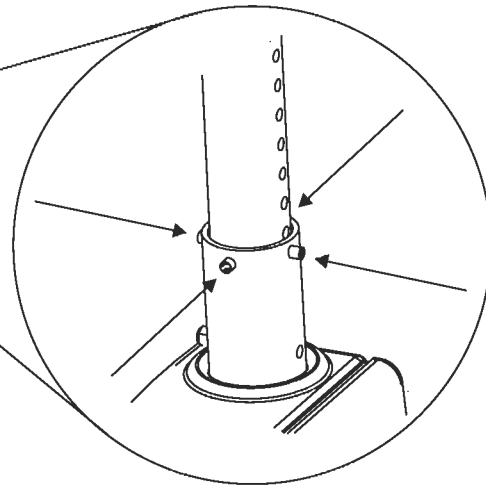

Providing the base can be mounted level, the set screws should be tightened equally all around. Tightened so that there is equal distance all around the two tubes and the post is vertical to the base.

Should the base be installed less than level, use these screws to bring the post back to vertically level.

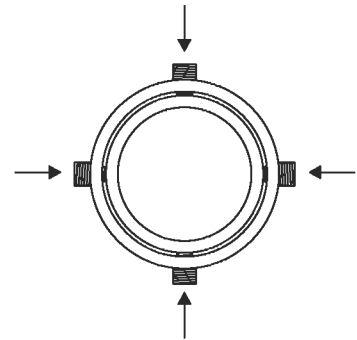

Should the strap begin to ride up the side of the roller while lifting the payload, check the set screws that center the post in the base.

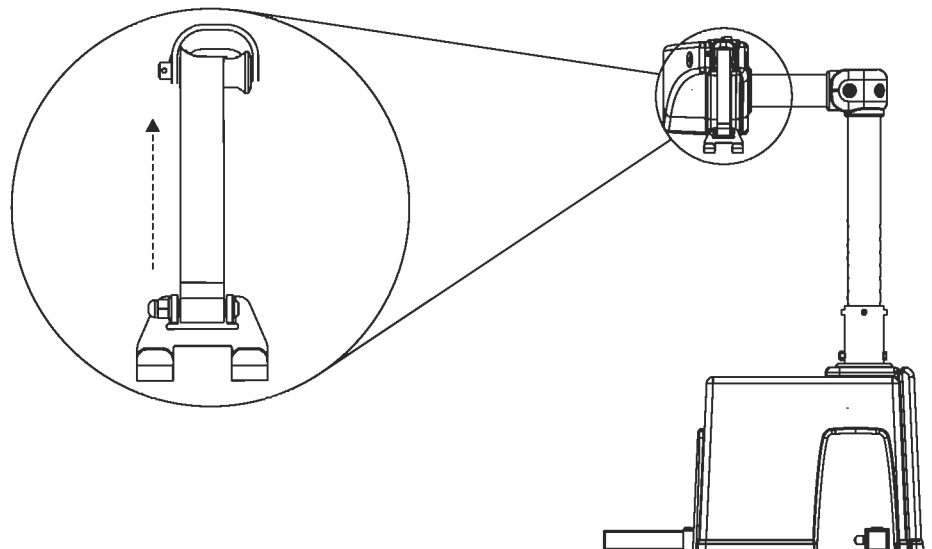

AL420 / 410 / 220 / 210 Wiring

Connect Hand Controller and Power Wiring
as shown below (dotted lines depict connections required)

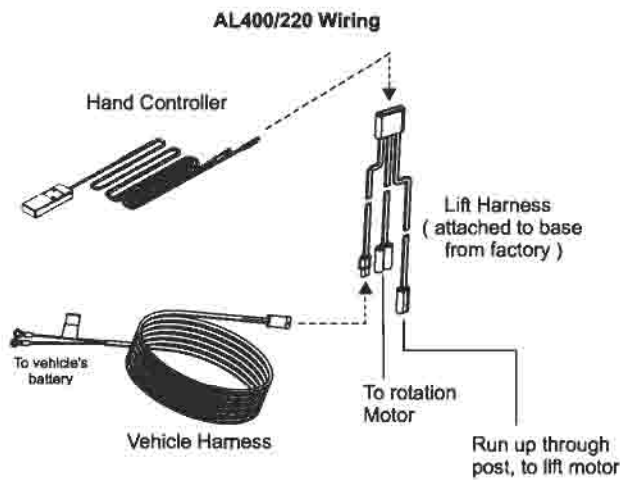
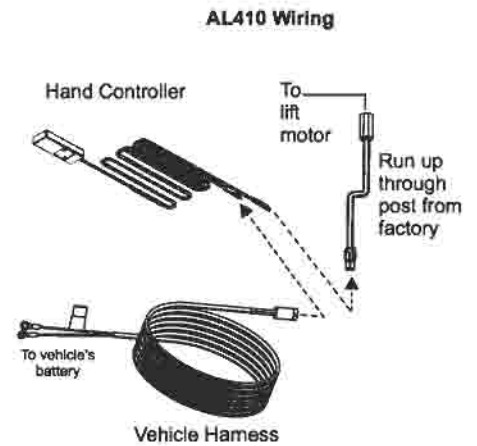
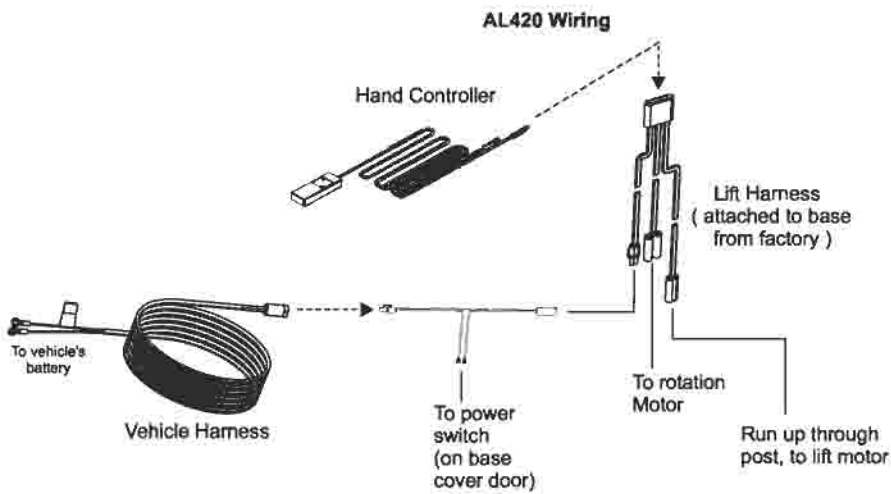

It is now possible to re-attach Lift Arm and Base covers
(if applicable) as the installation is complete.

Re-check all fasteners

Operational Guidelines:

- Inspect the Lifting Strap prior to each use. Contact your distributor if it shows signs of wear or fraying.
- Do not operate this lift until you dealer has satisfactorily instructed you in the proper operation of this lift.
- Always make sure the vehicle's parking brake is firmly set before operation.
- Keep hands and feet from under the scooter or power chair as it is being lifted.
- Take care not to hold one of the buttons on the Hand Controller until the Lifting Strap switches direction. The UP button should always pull the strap up and vice versa. If your buttons cause opposite movement, contact your distributor.

Loading your Scooter or Power Chair

Note: Due to the wide variety of scooters, power chairs and vehicles, your dealer may offer a different method for Loading and Unloading your scooter. Please follow the guidelines they have offered.

- Swing the Lifting Arm out of the vehicle toward the scooter or chair (using the Hand controller if equipped with power rotation)
- Maneuver the scooter parallel to the rear bumper and two inches behind the vehicle. Depending on the vehicle, it may be necessary to: remove the seat; fold down or remove the handle bar; remove accessories such as brackets, baskets, crutch holders, etc.
- With the docking device positioned directly under the Strap Hook, lower the Lifting Strap using the DOWN button on the Hand Control until the Strap Hook (or C-Arm) can be engaged into the docking device installed on the scooter or chair. Hook the docking device on the scooter or chair with the Strap Hook and remove any play in the strap by pushing the UP button on the Hand Control until tension is felt.

Caution: Ensure that the Lifting Strap is secure and taught and that it points straight down. Failure to do so could result in the scooter or chair swinging toward the operator or the vehicle.

- Raise the scooter or chair using the UP button until the scooter or chair is just above the highest obstacle. This is usually the van floor, door sill or tailgate.

Caution: Stop lifting before the Strap Hook contacts the Strap Roller mounted on the Lifting Arm. Contact will result in damage to the lift. A properly adjusted and operated lift will avoid this.

- Swing the scooter or chair into the vehicle (using the Hand controller if equipped with power rotation) ensuring that the scooter or chair does not contact the vehicle.
- With the scooter or chair positioned above its stowed position, lower the lift using the DOWN button on the Hand Controller. The scooter or chair should be lowered until it is sitting firmly on the floor but the strap should remain taut. This facilitates a quicker and easier unloading of the scooter later.

Caution: Ensure that the scooter or chair is firmly sitting on the floor and not suspended by the lift

If preparations need to be made to secure the scooter or power chair for transport, such as parking brakes or wheel chocks, do these now. Dealers should instruct operators on how, if necessary to secure the scooter or chair for transport. Place the Hand Control on the Velcro mounting pad and close the doors or tailgate and you are ready to go.

AL420 / 410 / 220 / 210

Operation

Unloading Your Scooter or Power Chair

- Undo any preparations made to secure the scooter or power chair for transport.
- Raise the scooter or chair by pressing the UP button on the Hand Control until the tires are high enough to clear the highest obstacle, usually the door sill or tailgate.

Caution: Stop lifting before the Strap Hook contacts the Strap Roller mounted on the Lifting Arm. Contact will result in damage to the lift. A properly adjusted and operated lift will avoid this.

- Swing the scooter or chair out of the vehicle (using the Hand controller if equipped with power rotation) carefully ensuring that the scooter does not contact the vehicle.
- With the scooter or chair positioned away from the vehicle, lower the lift using the DOWN button. Continue lowering the lift slightly beyond the scooter or chair touching the ground to allow removal of the Strap Hook from the docking device on the scooter.

Caution: Do not allow the scooter or chair to come in contact with the vehicle. Damage may result to both the vehicle AND the operator.

Replace anything removed from the scooter or chair for loading purposes. Swing the Lifting Arm back into the vehicle and place the Hand Control on the Velcro mounting pad. Close the doors or tailgate and you are ready to go.

AL420 / 410 / 220 / 210 Operation

(For AL410 and 210 models
substitute "IN" and "OUT"
function for manual rotation)

ALWAYS INSPECT THE LIFTING
STRAP PRIOR TO EACH USE
FOR DAMAGE OR WEAR



Press the "OUT" button
swinging the lift to the
outside of the vehicle

Position so the lifting strap
can be lowered to the
location of the chair

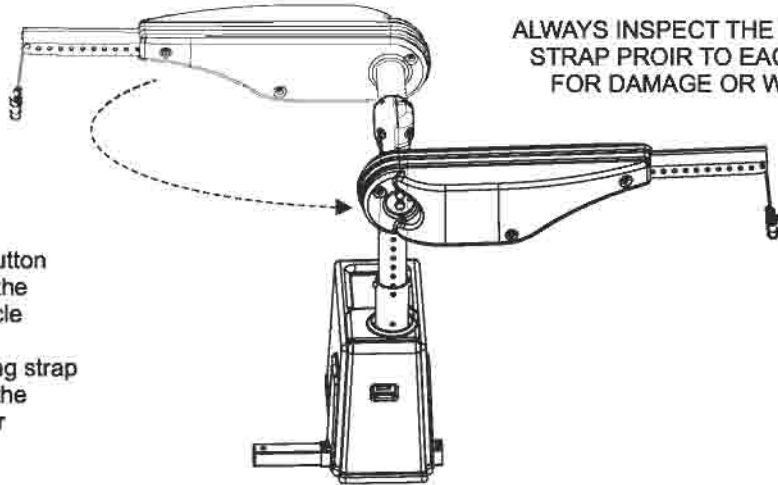

Press the "DOWN" Button
lowering the strap until it
can reach the docking
device of the chair

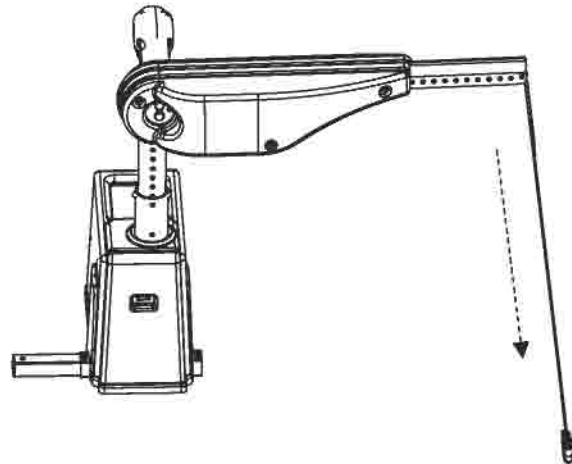

Secure the Lifting Strap to the
chair by placing the Strap hook
to the bar on the docking device.

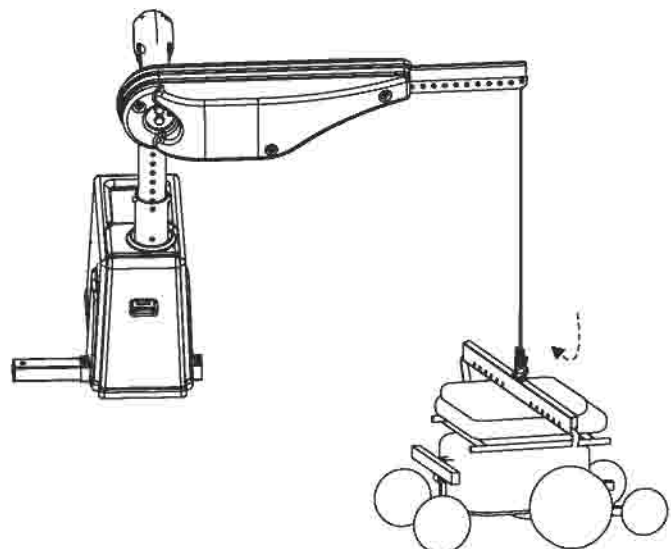

AL420 / 410 / 220 / 210 Operation



Press the "UP" button on the Hand Controller, raising the chair until it will clear the floor of the vehicle.

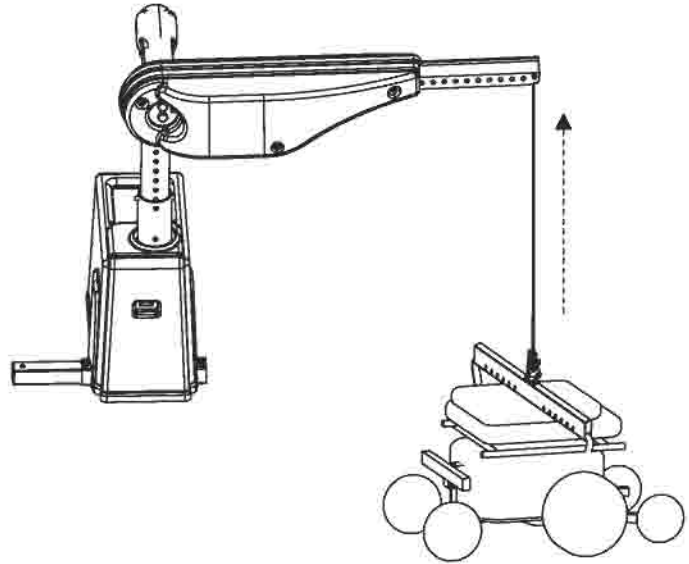

Press the "IN" button to rotate the chair into the vehicle until desired placement inside the vehicle is achieved.

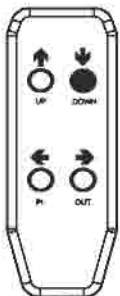
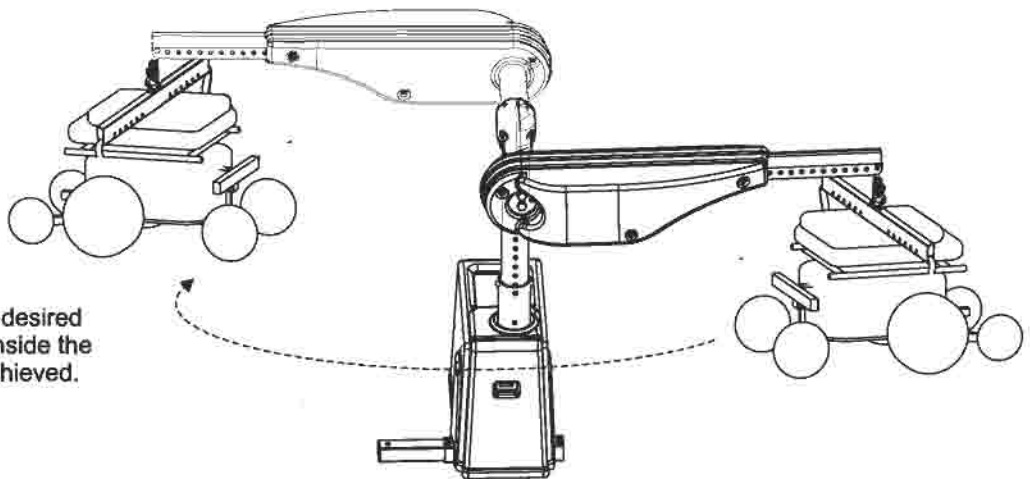

Press the "DOWN" button to lower the chair to the vehicle floor.

Once the chair has reached the floor and the lifting strap will have some "slack" to it. It is recommended to leave the strap attached during transport, and to take the "slack" out of the strap by pressing "UP" button just enough to straighten the strap but DO NOT lift the chair off the floor

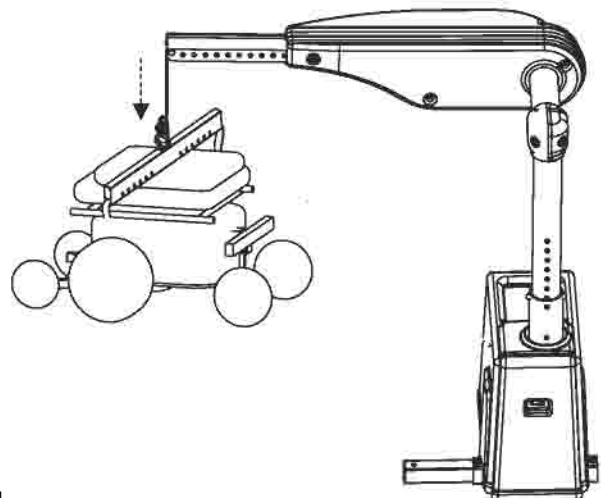

AL420 / 410 / 220 / 210 Safety and Maintenance

SAFETY:

- **Caution:** Do not operate this lift until your dealer has satisfactorily instructed you in the proper operation of the lift.
- Your Harmar Inside Lift has been engineered and designed for years of trouble free use. Although, with everyday use, some parts may become loose or worn. **IMPORTANT!** Check regularly for any worn, loose or damaged parts of your lift. **If anything is observed, DO NOT USE THE LIFT!** Contact your dealer or installer of the lift for repairs to be made. **Failure to act may cause severe injury!**
- Your Harmar Inside Lift should only be used for the loading and unloading of scooters and power wheelchairs for which it is designed. **DO NOT** add to or modify any part of the lift system without first contacting the manufacturer of the lift. Any modifications may void any warranties as well as effect the structural integrity of the lift.
- **ALWAYS CHECK THE LIFTING STRAP BEFORE EACH USE FOR DAMAGE OR WEAR.**
- Always make sure the vehicle's parking brake is firmly set before operating the lift.
- **Caution:** Insure that the Lifting Strap is secure and taught and that it points straight down before lifting of the scooter or power chair. Failure to do so could result in the scooter or chair swinging toward the operator of the vehicle.
- **Caution:** When using the lift, keep your hands and feet from under the scooter or power chair as it is being loaded or unloaded.
- **Caution:** Stop lifting before the Strap Hook contacts the Strap Roller mounted on the Lifting Arm. Contact will result in damage to the lift. A properly adjusted and operated lift will avoid this.
- **Caution:** Insure that the scooter or chair is firmly sitting on the floor of the vehicle and not suspended by the lift. If the scooter or power chair is not firmly on the floor of the vehicle, it may move during transportation and cause damage to the lift, scooter or power chair, vehicle, or passengers.

MAINTENANCE:

The Harmar Inside Lift has been designed to be as trouble free as possible for the owner. But, as with any mechanical device, regular care should be given while owning and using this device.

Maintenance is no exception.

- We recommend that dealers should schedule a preventative maintenance inspection at least once a year on motors, lift frame, wiring harness and all moving parts of the lift.
- Check for paint chips and touch up any bare metal with a good gloss black enamel or lacquer to inhibit rust. This may be necessary more frequently when subjected to salt air or road salt.
- Always check the lifting strap before each use. If any wear or fraying is noticed **DO NOT USE THE LIFT!** Contact the installer or dealer for repair. Failure to act may cause damage to the vehicle or severe injury!
- Hand control units should not be exposed to the weather. If the lift is mounted in the bed of a truck, remove the hand control between each use. Exposure to the elements may cause the unit to fail.

WARRANTY:

This lift is covered by a three year factory warranty on materials and workmanship. Contact your local dealer for more information or go to www.harmar.com for complete details.

AL420 / 410 / 220 / 210 Troubleshooting

Problem	Possible Cause	Suggestions
Lift does not operate Lift operates slowly	Electrical Connections	Verify that battery connections are clean with good contact. Inspect full length of wiring harness. Test the electrical connection by powering lift through a fully charged shop battery using a secondary harness.
Intermittent power to lift	Circuit Breaker	Circuit breaker resets itself automatically, to test for a malfunction check for power at the lift with a test lamp.
	Electrical Connections	See item #1 top of page
	Hand Control	Test by bypassing the hand control for 1-2 seconds. Caution: Damage to lift, mobility device or vehicle can occur if continuous power is supplied to the lift.
Lifting arm is slow to swing in and out (AL420 and AL220 only)	Dirty Bushings	Clean and apply new grease to white plastic bushings located in the base of the lift.
	Electrical Connections	See item #1 top of page
Lifting strap operates in reverse	Overextended Strap	The lifting strap could have been lowered too far, causing it to wind backwards. Lower strap until it unravels from spool, then raise in the proper direction.
Scooter/Power Chair tips while being lifted	Lifting Off-Center	The docking device should be positioned so that the lifting strap is over the center of gravity. This is normally near the center of the seat. Also confirm that correct docking device is being used.

AL200 / AL400 / AL055 Vehicle Preparation

The AL200 / 400 / 055 Lift has been designed with the shortest height and smallest footprint requirements to allow maximum room for the loading and unloading of your scooter or power chair. If there is 30" of headroom and room for the scooter or chair in the vehicle, then the AL200 / 400 should be able to be installed and operate properly. (The AL055 requires 37" of headroom unless the post is cut for smaller openings)

- To obtain the ideal mounting location and avoid possible interference, the lift should be pre-assembled and "trial fit" in the desired installation location. This procedure may require two people, one person to hold the lift in the desired position and another to move the Lifting Arm through its full range of motion. Please refer to the packaging checklist for the parts identification and exploded view of the lift. The Inside Lifts have been engineered so that it can easily be configured as a solution for most applications. This "trial fit" will also help you determine where the Vehicle Wiring Harness will be run.

Hint: It is always best to check with the customer when determining lift placement and ask permission before drilling through the vehicle's floor.

- **Typical Applications**
Car Trunk—AL055 or AL200 only
Rear Cargo Area—for most vans and SUV's.

Tailgate applications for SUV's, Station Wagons and Trucks using the offset arm conversion option. (AL200/400 only)

NOTE: The base should be mounted as far to the rear corner of the vehicle as possible in most rear mount applications. This allows for the maximum reach of the lifting arm.

There are some vehicles that, due to their setup, will not accommodate a standard lift installation. Please check for the following:

- Vehicle must have 30" **clear headroom** for operation for the AL200/400. Be sure and check during "trial fit" that a full range of motion can be achieved without any roof or lift gate interference. (37" headroom required for AL055)
- Spare tire storage—Some vehicles store the spare tire under the floor of the vehicle. Make sure that the base can be bolted through to a steel floor or frame.
- Some vehicles have been manufactured with a "false floor" which is made of composite materials. The lift must be anchored to a steel floor or frame.
- Trunk applications must be secured to a flat trunk floor. (AL055 only) Make sure that there are not deep wells in the trunk that will affect placement of the base. Most of these can be overcome.
- Offset Arm Applications (AL200/400) The offset arm allows the lifting arm to reach around to the side of the vehicle. This allows the loading and unloading of the scooter or power chair when there is a tailgate to contend with or when the base location does not allow a straight post to be used. Many times this application is referred to as a "curbside" installation.

Trial Fit Procedure:

- Place the assembled lift as it is configured in the shipping carton into the desired location.
When using the Offset Post Conversion (AL200/400), bolt the Lifting Arm to the Post using the supplied 3-3/4" Hex bolt and lock nut. The offset arm can be configured to left side or right side applications by bolting the Lifting Arm to the Offset Post in either orientation.
- Raise the Lifting Arm to achieve to an 1/8" clearance to the lowest point of the vehicle's roof that the Lifting Arm will encounter during its travel (usually the door opening or rear A/C vents).
- On the AL200/400, unscrew the Adjustable Link to provide the desired height of the Lifting Arm and bolt the two components together using the supplied 3/8" x 2" hex bolt, washers and 3/8" Stover lock nut—no nylon.
- Mark the desired position for installation.

AL200 Installation

You should have established a mounting position for the lift during the "trial fit" as described in this manual. If not, it is recommended that you go through that procedure.

- Mount the lift in the location determined during the "trial fit" in the vehicle. The Leg Extensions in the Base telescope in and out to avoid potential obstacles. For heavy application, pull the Leg Extensions out as far as is practical for increased base stability. Mark the 3 mounting hole locations or use the Base as a guide and drill holes using a 3/8" drill bit. Bolt the Base to the floor of the vehicle using the supplied 3/8" x 3" hex bolt in the corner, two 3/8" x 2" hex bolts for each Leg. Use the supplied multi-hole Installation Washers on the underside to help reinforce the vehicle's floor, see Figure #4.1. Replace an Installation Washer with a 3/8" fender washer if necessary due to size constraints. Secure the Telescoping Legs by tightening the 2 set screws on the inside of the base. Hint: Variations in the flatness of the vehicle's floor can be compensated for by adding 3/8" washers to the mounting hardware under the base. Always mount the base so it is level.

Caution! If the set screws on the base do not contact the Leg Extensions, they are telescoped out too far and must be moved into the Base further.

Caution! Avoid the vehicle wiring, fuel lines, fuel tanks, spare tires, etc. when drilling holes for mounting hardware!

- The Hand Control has two plugs on it. One, the male plug, attaches to the Vehicle Wiring Harness that was installed earlier. The other, the female plug, attaches to the motor on the lifting arm. At this time, reconnect the vehicle's ground (-) cable on the battery.
- Tie the long leads of the Hand Control Harness to the Post using the plastic ties where necessary. This step will be skipped when using the lift in a "Take Apart" configuration, as the Lifting Arm and the Post must be disassembled.
- Follow the Operator Instructions to Load and Unload the scooter or chair from the vehicle to test operation and clearances.
- Determine if the scooter or chair will need to be moved closer to the lift or further from the side of the vehicle. This will be done by adjusting the location of the Strap Roller on the Lifting Arm. The Lifting Arm is factory pre-assembled with the strap out at the furthest extent and may need to be adjusted to fit a particular application.
- Measure the distance the scooter should be moved to clear any obstacles.
- To move the Strap Roller, remove the Split Ring (like on a key chain) from the Clevis Pin. Pull out the Clevis Pin and Strap Roller and replace it in the desired hole location. Holes on the Lifting Arm are on one inch centers.
- Recheck all fasteners.

Refer to the instructions included with your docking device for information on preparing the scooter or power chair for use with the Universal Inside Lift.

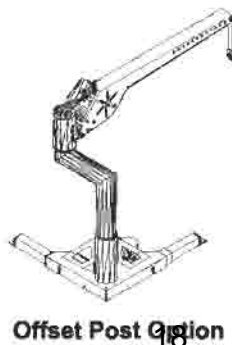
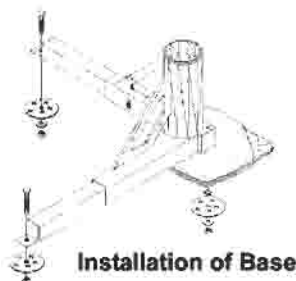

Trunk Applications:

Operational Guidelines:

- Inspect the Lifting Strap prior to each use. Contact your distributor if it shows signs of wear or fraying.
- Do not operate this lift until you dealer has satisfactorily instructed you in the proper operation of this lift.
- Always make sure the vehicle's parking brake is firmly set before operation
- Keep hands and feet from under the scooter or power chair as it is being lifted.
- Take care not to hold one of the buttons on the Hand Controller until the Lifting Strap switches direction. The UP button should always pull the strap up and vice versa. If your buttons cause opposite movement, contact your distributor.

Loading your Scooter or Power Chair —Trunk Applications

Note: Due to the wide variety of scooters, power chairs and vehicles, your dealer may offer a different method for Loading and Unloading your scooter. Please follow the guidelines they have offered.

- To assemble your lift, begin by inserting the Post into the Base mounted on the floor. Next, slide the Lifting Arm onto the top of the Post.
- Plug the Hand Control into the lifting arm and into the Vehicle Harness.
- Swing the Lifting Arm out of the vehicle toward the scooter.
- Maneuver the scooter parallel to the rear bumper and two inches behind the vehicle. Depending on the vehicle, it may be necessary to: remove the seat; fold down or remove the handle bar; remove accessories such as brackets, baskets, crutch holders, etc.
- With the docking device positioned directly under the Strap Hook, lower the Lifting Strap using the DOWN button on the Hand Control until the Strap Hook can be engaged into the docking device installed on the scooter or chair. Hook the docking device on the scooter or chair with the Strap Hook and remove any play in the strap by pushing the UP button on the Hand Control until tension is felt.

Caution: Ensure that the Lifting Strap is secure and taught and that it points straight down. Failure to do so could result in the scooter or chair swinging toward the operator of the vehicle.

- Raise the scooter or chair using the UP button until the scooter or chair is just above the trunk lip.

Caution: Stop lifting before the Strap Hook contacts the Strap Roller mounted on the Lifting Arm. Contact will result in damage to the lift. A properly adjusted and operated lift will avoid this.

- Swing the scooter or chair into the vehicle, ensuring that the scooter or chair does not contact the vehicle.
- With the scooter or chair positioned above its stowed position, lower the lift using the DOWN button on the Hand Controller. Continue lowering the Strap Hook slightly beyond the scooter touching the floor to allow removal of the Strap Hook from the Docking Device on the scooter or chair.
- To disassemble the lift, first raise the strap until the freed Strap Hook is about an inch away from the Lifting Arm. Unplug the Hand Control harness from both the Vehicle Harness and the Lifting Arm
- Pull the Lifting Arm off the Post and lay it on the floor of the trunk. Then, pull the Post out of the Base using the handle and set it down with the Lifting Arm.

AL200

Operation

Trunk Applications

- If preparations needed to be made to secure the scooter or chair for transport, such as parking brakes or wheel chocks, do these now. Dealers should instruct operators on how, if necessary, to secure the scooter or chair for transport. Close the trunk and you are ready to go.

Unloading Your Scooter or Power Chair —Trunk Applications

- Undo any preparations made to secure the scooter or power chair for transport.
- To assemble your lift, begin by inserting the Post into the Base mounted on the floor. Next, slide the Lifting Arm onto the Post.
- Plug in the Hand Control.
- By pressing the DOWN button on the Hand Control harness, run the Strap Hook down until it is slightly lower than the docking device on the scooter.
- Attach the Strap Hook to the docking device on the scooter or chair and remove any play in the strap by pressing the UP button on the Hand Control until tension is felt.

Caution: *Ensure that the Lifting Strap is secure and taught and that it points straight down. Failure to do so could result in the scooter or chair swinging toward the vehicle or operator.*

- Raise the scooter or power chair using the UP button until the scooter or chair is just above the trunk lip.

Caution: *Stop lifting before the Strap Hook contacts the Strap Roller mounted on the Lifting Arm. Contact will result in damage to the lift. A properly adjusted and operated lift will avoid this.*

- Swing the scooter or chair out of the vehicle, carefully ensuring that the scooter does not contact the vehicle.
- With the scooter or chair positioned away from the vehicle, lower the lift using the DOWN button. Continue lowering the lift slightly beyond the scooter or chair touching the ground to allow removal of the Strap Hook from the docking device on the scooter.
- To disassemble the lift, first raise the Lifting Strap until the freed Strap Hook is about an inch away from the Lifting Arm. Unplug the Hand Control harness from both the Vehicle Harness and the Lifting Arm.
- Pull the Lifting Arm off of the Post and lay it on the floor of the trunk. Then pull the Post out of the Base using the handle and set it down with the Lifting Arm.

Replace anything removed from the scooter or chair for loading purposes. Close the trunk and you are ready to go.

Enclosed Vehicle Applications:

Operational Guidelines:

- Inspect the Lifting Strap prior to each use. Contact your distributor if it shows signs of wear or fraying.
- Do not operate this lift until you dealer has satisfactorily instructed you in the proper operation of this lift.
- Always make sure the vehicle's parking brake is firmly set before operation.
- Keep hands and feet from under the scooter or power chair as it is being lifted.
- Take care not to hold one of the buttons on the Hand Controller until the Lifting Strap switches direction. The UP button should always pull the strap up and vice versa. If your buttons cause opposite movement, contact your distributor.

Loading your Scooter or Power Chair —Enclosed Vehicle Applications

Note: Due to the wide variety of scooters, power chairs and vehicles, your dealer may offer a different method for Loading and Unloading your scooter. Please follow the guidelines they have offered.

- Unhook the Strap Hook or optional C-Arm from the gusset on the Base (recommended stowed position).
- Swing the Lifting Arm out of the vehicle toward the scooter.
- Maneuver the scooter parallel to the rear bumper and two inches behind the vehicle. Depending on the vehicle, it may be necessary to: remove the seat; fold down or remove the handle bar; remove accessories such as brackets, baskets, crutch holders, etc.

Note: When using the Offset Post Conversion, position the scooter on the side of the vehicle parallel to the vehicle with the front tires even with the vehicle's rear bumper.

- With the docking device positioned directly under the Strap Hook, lower the Lifting Strap using the DOWN button on the Hand Control until the Strap Hook (or C-Arm) can be engaged into the docking device installed on the scooter or chair. Hook the docking device on the scooter or chair with the Strap Hook and remove any play in the strap by pushing the UP button on the Hand Control until tension is felt.

Caution: Ensure that the Lifting Strap is secure and taut and that it points straight down. Failure to do so could result in the scooter or chair swinging toward the operator of the vehicle.

- Raise the scooter or chair using the UP button until the scooter or chair is just above the highest obstacle. This is usually the van floor, door sill or tailgate.

Caution: Stop lifting before the Strap Hook contacts the Strap Roller mounted on the Lifting Arm. Contact will result in damage to the lift. A properly adjusted and operated lift will avoid this.

- Swing the scooter or chair into the vehicle, ensuring that the scooter or chair does not contact the vehicle.
- With the scooter or chair positioned above its stowed position, lower the lift using the DOWN button on the Hand Controller. The scooter or chair should be lowered until it is sitting firmly on the floor but the strap should remain taut. This facilitates a quicker and easier unloading of the scooter later.

Caution: Ensure that the scooter or chair is firmly sitting on the floor and not suspended by the lift

If preparations need to be made to secure the scooter or power chair for transport, such as parking brakes or wheel chocks, do these now. Dealers should instruct operators on how, if necessary to secure the scooter or chair for transport. Place the Hand Control on the Velcro mounting pad and close the doors or tailgate and you are ready to go.

AL200 Operation

Enclosed Vehicle Applications

Unloading Your Scooter or Power Chair —Enclosed Vehicle Applications

- Undo any preparations made to secure the scooter or power chair for transport.
- Raise the scooter or chair by pressing the UP button on the Hand Control until the tires are high enough to clear the highest obstacle, usually the door sill or tailgate.

Caution: *Stop lifting before the Strap Hook contacts the Strap Roller mounted on the Lifting Arm. Contact will result in damage to the lift. A properly adjusted and operated lift will avoid this.*

- Swing the scooter or chair out of the vehicle, carefully ensuring that the scooter does not contact the vehicle.
- With the scooter or chair positioned away from the vehicle, lower the lift using the DOWN button. Continue lowering the lift slightly beyond the scooter or chair touching the ground to allow removal of the Strap Hook from the docking device on the scooter.

Caution: *Do not allow the scooter or chair to come in contact with the vehicle. Damage may result to both the vehicle AND the operator.*

Replace anything removed from the scooter or chair for loading purposes. Swing the Lifting Arm back into the vehicle and place the Hand Control on the Velcro mounting pad. Close the doors or tailgate and you are ready to go.

AL400 Installation

- You should have established a mounting position for the lift during the "trial fit" as described previously in this manual. If not, it is recommended that you go through that procedure.

Note: The Base should be mounted as far to the rear corner of the vehicle as possible in most rear mount applications.

- Mount the lift in the location determined during the "trial fit" in the vehicle. The Leg Extensions in the Base telescope in and out to avoid potential obstacles. For heavy applications, pull the Leg Extensions out as far as is practical for increased base stability. Mark the 3 mounting hole locations or use the Base as a guide and drill holes using a 3/8" drill bit. Bolt the Base to the floor of the vehicle using the supplied 3/8" x 3" hex bolt in the corner, two 3/8" x 2" hex bolts for each Leg. Use the supplied multi-hole Installation Washers on the underside to help reinforce the vehicle's floor, see below. Replace an Installation Washer with a 3/8" fender washer if necessary due to size constraints. Secure the Telescoping Legs by tightening the 2 set screws on the inside of the base.

Hint: Variations in the flatness of the vehicle's floor can be compensated for by adding 3/8" washers to the mounting hardware under the base. **VERY IMPORTANT!!! Always mount the base so it is level.**

Caution! If the set screws on the base do not contact the Leg Extensions, they are telescoped out too far and must be moved into the Base further.

Caution! Avoid the vehicle wiring, fuel lines, fuel tanks, spare tires, etc. when drilling holes for mounting hardware!

Power Base

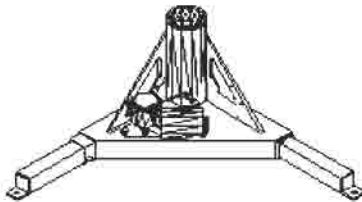

Installation of Base

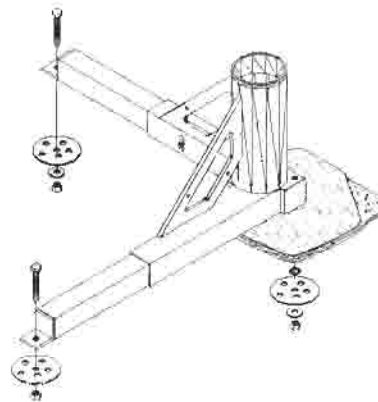

- Place the assembled lift as it is configured in the shipping carton into the desired location.
- Bolt the Lifting Arm to the Post using the supplied 5/16" x 3-3/4" hex bolt and lock nut.
- Raise the Lifting Arm to achieve an 1/8" clearance to the lowest point of the vehicle's roof that the lifting arm will encounter during its travel (usually the door opening or rear A/C vents).
- Unscrew the Adjustable Link to provide the desired height of the lifting Arm and bolt the two components together using the supplied 3/8" x 2" hex bolt, two 3/8" washers and one 3/8" Stover lock nut (no nylon).
- Plug the 6 prong connector on the Hand Control into the 6 prong plug on the Hand Control harness located near the base of the lift. This quick connect plug will allow you to remove the Hand Control while not in use if desired.

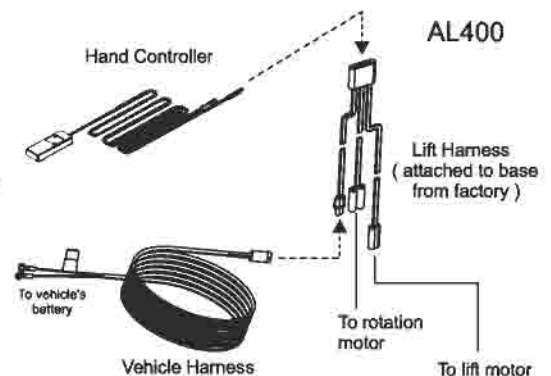

AL400 Installation

IMPORTANT! Make sure that the Post is seated completely down into the white PowerBase bushing. If there is any wobble to the post, rotate it in the base bushing until it drops completely onto the pin located in the bottom of the base unit. **DO NOT ATTEMPT TO OPERATE THE LIFT IF THE POST IS NOT SECURELY SEATED IN THE BASE!** THIS MAY CAUSE DAMAGE TO THE ROTATING MOTOR AND WILL NOT BE COVERED UNDER WARRANTY!

NOTE: The lift is factory set to rotate 190 degrees for passenger (right) side applications. However, the lift can be configured for right or left side applications by changing the orientation of the Post. This can be accomplished using the following steps:

1. Pull out the Ringed Quick Pin from the bottom of the Post
2. Press the OUT button until the motor hits the rotation limit and stops rotation (the lift stops itself). Because the Quick Pin is removed, the Lifting Arm is not coupled to the Power Base and may not turn on its own. Position the Lifting Arm manually so it is pointing straight out the back of the vehicle.

Offset Post Option

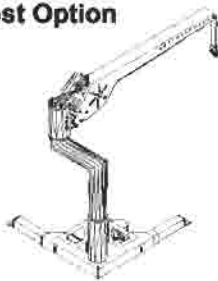

Adjustable Strap

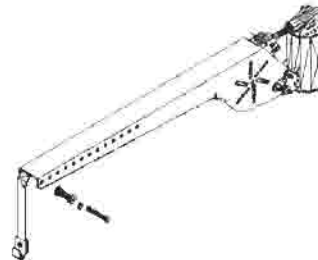

3. The hole for the Pin in the Post should be lined up to allow the bolt to be inserted. Insert the Pin. You may need to rotate the Lifting Arm slightly to get the holes to line up.
4. Using the Hand Control, swing the Lifting Arm through its entire range of motion to check for interference. Also, close any doors to check that the lift does not interfere. Adjust the Power Base location and Lifting Arm height as necessary. The Lifting Arm should rotate until it is pointing straight out the back of the vehicle and then stop itself.

NOTE: When using the Offset Arm Conversion, the Lifting Arm should rotate until it is pointing perpendicular to the side of the vehicle and stop itself. Also, pay particular attention that the Lifting Arm rotates in far enough to load the scooter.

- Follow the Operator Instructions to Load and Unload the scooter or chair from the vehicle to test operation and clearances.
- Determine if the scooter or chair will need to be moved closer to the lift or further from the side of the vehicle. This will be done by adjusting the location of the Strap Roller on the Lifting Arm. The Lifting Arm is factory pre-assembled with the strap out at the furthest extent and may need to be adjusted to fit a particular application.
- Measure the distance the scooter should be moved to clear any obstacles.
- To move the Strap Roller, remove the Split Ring (like on a key chain) from the Clevis Pin. Pull out the Clevis Pin and Strap Roller and replace it in the desired hole location. Holes on the Lifting Arm are on one inch centers.
- Recheck all fasteners.

Refer to the instructions included with your docking device for information on preparing the scooter or power chair for use with the Universal Inside Lift.

Operational Guidelines:

- Inspect the Lifting Strap prior to each use. Contact your distributor if it shows signs of wear or fraying.
- Do not operate this lift until you dealer has satisfactorily instructed you in the proper operation of this lift.
- Always make sure the vehicle's parking brake is firmly set before operation.
- Keep hands and feet from under the scooter or power chair as it is being lifted.
- Take care not to hold one of the buttons on the Hand Control until the Lifting Strap switches direction. The UP button should always pull the strap up and vice versa. If your buttons cause opposite movement, contact your distributor.

Loading your Scooter or Power Chair

Note: Due to the wide variety of scooters, powerchairs and vehicles, your dealer may offer a different method for Loading and Unloading your scooter. Please follow the guidelines they have offered.

Note: The Hand Control may be removed between uses by unplugging the 6 prong plug from the hand control harness. Simply reverse this process to reattach the Hand Control to the lift. The lift can not be operated without the Hand Control plugged in.

- Unhook the Strap Hook or optional C-Arm from the gusset on the Base (recommended stowed position).
- Using the OUT button on the Hand Control, swing the Lifting Arm out of the vehicle toward the scooter.
- Maneuver the scooter parallel to the rear bumper and two inches behind the vehicle. Depending on the vehicle, it may be necessary to: remove the seat; fold down or remove the handle bar; remove accessories such as brackets, baskets, crutch holders, etc.

Note: When using the Offset Post Conversion, position the scooter on the side of the vehicle parallel to the vehicle with the front tires even with the vehicle's rear bumper.

- If preparations need to be made to secure the scooter or power chair for transport, such as parking brakes or wheel chocks, do these now. Dealers should instruct operators on how, if necessary to secure the scooter or chair for transport. Hook the Hand Control on the top of the Post and close the doors or tailgate and you are ready to go.
- With the docking device positioned directly under the Strap Hook, lower the Lifting Strap using the DOWN button on the Hand Control until the Strap Hook (or C-Arm) can be engaged into the docking device installed on the scooter or chair. Hook the docking device on the scooter or chair with the Strap Hook and remove any play in the strap by pushing the UP button on the Hand Control until tension is felt.

Caution: Insure that the Lifting Strap is secure and taut and that it points straight down. Failure to do so could result in the scooter or chair swinging toward the operator of the vehicle.

- Raise the scooter or chair using the UP button until the scooter or chair is just above the highest obstacle. This is usually the van floor, door sill or tailgate.

Caution: Stop lifting before the Strap Hook contacts the Strap Roller mounted on the Lifting Arm. Contact will result in damage to the lift. A properly adjusted and operated lift will avoid this.

- Using the IN button on the Hand Control, swing the scooter or chair into the vehicle, insuring that the scooter or chair does not contact the vehicle.
- With the scooter or chair positioned above its stowed position, lower the lift using the DOWN button on the Hand Controller. The scooter or chair should be lowered until it is sitting firmly on the floor but the strap should remain taut. This facilitates a quicker and easier unloading of the scooter later.

Caution: Insure that the scooter or chair is firmly sitting on the floor and not suspended by the lift.

AL400

Operation

Unloading Your Scooter or Power Chair

- Undo any preparations made to secure the scooter or power chair for transport.
- Raise the scooter or chair by pressing the UP button on the Hand Control until the tires are high enough to clear the highest obstacle, usually the door sill or tailgate.

Caution: *Stop lifting before the Strap Hook contacts the Strap Roller mounted on the Lifting Arm. Contact will result in damage to the lift. A properly adjusted and operated lift will avoid this.*

- Using the OUT button on the Hand Control, swing the scooter or chair out of the vehicle, carefully insuring that the scooter does not contact the vehicle.
- With the scooter or chair positioned away from the vehicle, lower the lift using the DOWN button. Continue lowering the lift slightly beyond the scooter or chair touching the ground to allow removal of the Strap Hook from the docking device on the scooter.

Caution: *Do not allow the scooter or chair to come in contact with the vehicle. Damage may result to both the vehicle AND the operator.*

Replace anything removed from the scooter or chair for loading purposes. Raise the strap first using the IN button on the Hand Control and swing the Lifting Arm back into the vehicle. Close the doors or tailgate and you are ready to go.

AL055 Installation

- You should have established a mounting position for the lift during the "trial fit" as described earlier in this manual. If not, it is recommended that you go through that procedure.
- Mount the lift in the location determined during the "trial fit" in the vehicle. Mark the 3 mounting hole locations or use the Base as a guide and drill holes using a 3/8" drill bit. Bolt the Base to the floor of the vehicle using the supplied 3/8" x 3" hex bolt in the corner, two 3/8" x 2" hex bolts for each Leg. Use the supplied multi-hole Installation Washers on the underside to help reinforce the vehicle's floor, see below. Replace an Installation Washer with a 3/8" fender washer if necessary due to size constraints. Secure the Legs by tightening the 2 set screws on the inside of the base.

Hint: Variations in the flatness of the vehicle's floor can be compensated for by adding 3/8" washers to the mounting hardware under the base. Always mount the base so it is level.

Caution! Avoid the vehicle wiring, fuel lines, fuel tanks, spare tires, etc. when drilling holes for mounting hardware!

- Once the base has been mounted, place the Post into the nylon bushing that is located in the base.
- When the Post is properly seated in the Base, place the Lifting Arm onto the Post until it rests on the Adjustment Collar located on the Post. Adjust the height of the Lifting Arm by loosening the hex allen screw on the Adjustment Collar, move the Lifting Arm to the desired height and retighten the collar.

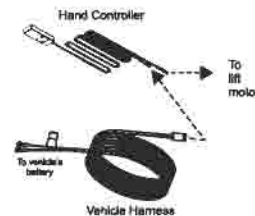

- The Hand Control has two plugs on it. The male plug attaches to the Vehicle Wiring Harness that was installed on the lifting arm. At this time, reconnect the vehicle's earlier. The other, the female plug, attaches to the motor ground (-) cable on the battery.
- Tie the long leads of the Hand Control Harness to the Post using the plastic ties where necessary. This step will be skipped when using the lift in a "Take Apart" configuration, as the Lifting Arm and the Post must be disassembled.
- Follow the Operator Instructions in this section to Load and Unload the scooter or chair from the vehicle to test operation and clearances.
- Determine if the scooter or chair will need to be moved closer to the lift or further from the side of the vehicle. This will be done by adjusting the location of the Strap Roller on the Lifting Arm. The Lifting Arm is factory pre-assembled with the strap out at the furthest extent and may need to be adjusted to fit a particular application.
- Measure the distance the scooter should be moved to clear any obstacles.
- To move the Strap Roller, remove the Split Ring (like on a key chain) from the Clevis Pin. Pull out the Clevis Pin and Strap Roller and replace it in the desired hole location. Holes on the Lifting Arm are on one inch centers. See below.

Base Installation

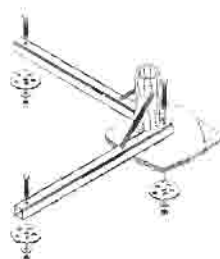

Adjustable Strap



- Recheck all fasteners.

Refer to the instructions included with your docking device for information on preparing the scooter or power chair for use with the Universal Inside Lift.

AL055

Operation

Operational Guidelines:

- Inspect the Lifting Strap prior to each use. Contact your distributor if it shows signs of wear or fraying.
- Do not operate this lift until you dealer has satisfactorily instructed you in the proper operation of this lift.
- Always make sure the vehicle's parking brake is firmly set before operation.
- Keep hands and feet from under the scooter or power chair as it is being lifted.
- Take care not to hold one of the buttons on the Hand Controller until the Lifting Strap switches direction. The UP button should always pull the strap up and vice versa. If your buttons cause opposite movement, contact your distributor.

Loading your Scooter or Power Chair —Trunk Applications

Note: Due to the wide variety of scooters, power chairs and vehicles, your dealer may offer a different method for Loading and Unloading your scooter. Please follow the guidelines they have offered.

- To assemble your lift, begin by inserting the Post into the Base mounted on the floor. Next, slide the Lifting Arm onto the top of the Post.
- Plug the Hand Control into the lifting arm and into the Vehicle Harness.
- Swing the Lifting Arm out of the vehicle toward the scooter.
- Maneuver the scooter parallel to the rear bumper and two inches behind the vehicle. Depending on the vehicle, it may be necessary to: remove the seat; fold down or remove the handle bar; remove accessories such as brackets, baskets, crutch holders, etc.
- With the docking device positioned directly under the Strap Hook, lower the Lifting Strap using the DOWN button on the Hand Control until the Strap Hook can be engaged into the docking device installed on the scooter or chair. Hook the docking device on the scooter or chair with the Strap Hook and remove any play in the strap by pushing the UP button on the Hand Control until tension is felt.

Caution: Ensure that the Lifting Strap is secure and taught and that it points straight down. Failure to do so could result in the scooter or chair swinging toward the operator of the vehicle.

- Raise the scooter or chair using the UP button until the scooter or chair is just above the trunk lip.

Caution: Stop lifting before the Strap Hook contacts the Strap Roller mounted on the Lifting Arm. Contact will result in damage to the lift. A properly adjusted and operated lift will avoid this.

- Swing the scooter or chair into the vehicle, ensuring that the scooter or chair does not contact the vehicle.
- With the scooter or chair positioned above its stowed position, lower the lift using the DOWN button on the Hand Controller. Continue lowering the Strap Hook slightly beyond the scooter touching the floor to allow removal of the Strap Hook from the Docking Device on the scooter or chair.
- To disassemble the lift, first raise the strap until the freed Strap Hook is about an inch away from the Lifting Arm. Unplug the Hand Control harness from both the Vehicle Harness and the Lifting Arm
- Pull the Lifting Arm off the Post and lay it on the floor of the trunk. Then, pull the Post out of the Base and set it down with the Lifting Arm.

Trunk Applications:

- If preparations needed to be made to secure the scooter or chair for transport, such as parking brakes or wheel chocks, do these now. Dealers should instruct operators on how, if necessary, to secure the scooter or chair for transport. Close the trunk and you are ready to go.

Unloading Your Scooter or Power Chair—Trunk Applications

- Undo any preparations made to secure the scooter or power chair for transport.
- To assemble your lift, begin by inserting the Post into the Base mounted on the floor. Next, slide the Lifting Arm onto the Post.
- Plug in the Hand Control.
- By pressing the DOWN button on the Hand Control harness, run the Strap Hook down until it is slightly lower than the docking device on the scooter.
- Attach the Strap Hook to the docking device on the scooter or chair and remove any play in the strap by pressing the UP button on the Hand Control until tension is felt.

Caution: *Ensure that the Lifting Strap is secure and taught and that it points straight down. Failure to do so could result in the scooter or chair swinging toward the vehicle or operator.*

- Raise the scooter using the UP button until the scooter or chair is just above the trunk lip.

Caution: *Stop lifting before the Strap Hook contacts the Strap Roller mounted on the Lifting Arm. Contact will result in damage to the lift. A properly adjusted and operated lift will avoid this.*

- Swing the scooter or chair out of the vehicle, carefully ensuring that the scooter does not contact the vehicle.
- With the scooter or chair positioned away from the vehicle, lower the lift using the DOWN button. Continue lowering the lift slightly beyond the scooter or chair touching the ground to allow removal of the Strap Hook from the docking device on the scooter.
- To disassemble the lift, first raise the Lifting Strap until the freed Strap Hook is about an inch away from the Lifting Arm. Unplug the Hand Control harness from both the Vehicle Harness and the Lifting Arm.
- Pull the Lifting Arm off of the Post and lay it on the floor of the trunk. Then pull the Post out of the Base and set it down with the Lifting Arm.

Replace anything removed from the scooter or chair for loading purposes. Close the trunk and you are ready to go.

AL055

Operation

Enclosed Vehicle Applications:

Operational Guidelines:

- Inspect the Lifting Strap prior to each use. Contact your distributor if it shows signs of wear or fraying.
- Do not operate this lift until you dealer has satisfactorily instructed you in the proper operation of this lift.
- Always make sure the vehicle's parking brake is firmly set before operation.
- Keep hands and feet from under the scooter or power chair as it is being lifted.
- Take care not to hold one of the buttons on the Hand Controller until the Lifting Strap switches direction. The UP button should always pull the strap up and vice versa. If your buttons cause opposite movement, contact your distributor.

Loading your Scooter—Enclosed Vehicle Applications

Note: Due to the wide variety of scooters, power chairs and vehicles, your dealer may offer a different method for Loading and Unloading your scooter. Please follow the guidelines they have offered.

- Unhook the Strap Hook or optional C-Arm from the gusset on the Base (recommended stowed position).
- Swing the Lifting Arm out of the vehicle toward the scooter.
- Maneuver the scooter parallel to the rear bumper and two inches behind the vehicle. Depending on the vehicle, it may be necessary to: remove the seat; fold down or remove the handle bar; remove accessories such as brackets, baskets, crutch holders, etc.

Note: When using the Offset Post Conversion, position the scooter on the side of the vehicle parallel to the vehicle with the front tires even with the vehicle's rear bumper.

- With the docking device positioned directly under the Strap Hook, lower the Lifting Strap using the DOWN button on the Hand Control until the Strap Hook (or C-Arm) can be engaged into the docking device installed on the scooter or chair. Hook the docking device on the scooter or chair with the Strap Hook and remove any play in the strap by pushing the UP button on the Hand Control until tension is felt.

Caution: Ensure that the Lifting Strap is secure and taught and that it points straight down. Failure to do so could result in the scooter or chair swinging toward the operator of the vehicle.

- Raise the scooter or chair using the UP button until the scooter or chair is just above the highest obstacle. This is usually the van floor, door sill or tailgate.

Caution: Stop lifting before the Strap Hook contacts the Strap Roller mounted on the Lifting Arm. Contact will result in damage to the lift. A properly adjusted and operated lift will avoid this.

- Swing the scooter or chair into the vehicle, ensuring that the scooter or chair does not contact the vehicle.
- With the scooter or chair positioned above its stowed position, lower the lift using the DOWN button on the Hand Controller. The scooter or chair should be lowered until it is sitting firmly on the floor but the strap should remain taut. This facilitates a quicker and easier unloading of the scooter later.

Caution: Ensure that the scooter or chair is firmly sitting on the floor and not suspended by the lift

If preparations need to be made to secure the scooter or power chair for transport, such as parking brakes or wheel chocks, do these now. Dealers should instruct operators on how, if necessary to secure the scooter or chair for transport. Place the Hand Control on the Velcro mounting pad and close the doors or tailgate and you are ready to go.

Enclosed Vehicle Applications:

Unloading Your Scooter—Enclosed Vehicle Applications

- Undo any preparations made to secure the scooter or power chair for transport.
- Raise the scooter or chair by pressing the UP button on the Hand Control until the tires are high enough to clear the highest obstacle, usually the door sill or tailgate.

Caution: *Stop lifting before the Strap Hook contacts the Strap Roller mounted on the Lifting Arm. Contact will result in damage to the lift. A properly adjusted and operated lift will avoid this.*

- Swing the scooter or chair out of the vehicle, carefully ensuring that the scooter does not contact the vehicle.
- With the scooter or chair positioned away from the vehicle, lower the lift using the DOWN button. Continue lowering the lift slightly beyond the scooter or chair touching the ground to allow removal of the Strap Hook from the docking device on the scooter.

Caution: *Do not allow the scooter or chair to come in contact with the vehicle. Damage may result to both the vehicle AND the operator.*

Replace anything removed from the scooter or chair for loading purposes. Swing the Lifting Arm back into the vehicle and place the Hand Control on the Velcro mounting pad. Close the doors or tailgate and you are ready to go.

PLEASE PROCEED TO SAFETY AND MAINTENANCE INFORMATION.

AL200 / AL400 / AL055

Safety and Maintenance

SAFETY:

- **Caution:** Do not operate this lift until your dealer has satisfactorily instructed you in the proper operation of the lift.
- Your Harmar Inside Lift has been engineered and designed for years of trouble free use. Although, with every-day use, some parts may become loose or worn. **IMPORTANT!** Check regularly for any worn, loose or damaged parts of your lift. **If anything is observed, DO NOT USE THE LIFT!** Contact your dealer or installer of the lift for repairs to be made. **Failure to act may cause severe injury!**
- Your Harmar Inside Lift should only be used for the loading and unloading of scooters and power wheelchairs for which it is designed. DO NOT add to or modify any part of the lift system without first contacting the manufacturer of the lift. Any modifications may void any warranties as well as effect the structural integrity of the lift.
- **ALWAYS CHECK THE LIFTING STRAP BEFORE EACH USE FOR DAMAGE OR WEAR.**
- Always make sure the vehicle's parking brake is firmly set before operating the lift.
- **Caution:** Insure that the Lifting Strap is secure and taught and that it points straight down before lifting of the scooter or power chair. Failure to do so could result in the scooter or chair swinging toward the operator of the vehicle.
- **Caution:** When using the lift, keep your hands and feet from under the scooter or power chair as it is being loaded or unloaded.
- **Caution:** Stop lifting before the Strap Hook contacts the Strap Roller mounted on the Lifting Arm. Contact will result in damage to the lift. A properly adjusted and operated lift will avoid this.
- **Caution:** Insure that the scooter or chair is firmly sitting on the floor of the vehicle and not suspended by the lift. If the scooter or power chair is not firmly on the floor of the vehicle, it may move during transportation and cause damage to the lift, scooter or power chair, vehicle, or passengers.

MAINTENANCE:

The Harmar Inside Lift has been designed to be as trouble free as possible for the owner. But, as with any mechanical device, regular care should be given while owning and using this device.

Maintenance is no exception.

- We recommend that dealers should schedule a preventative maintenance inspection at least once a year on motors, lift frame, wiring harness and all moving parts of the lift.
- Check for paint chips and touch up any bare metal with a good gloss black enamel or lacquer to inhibit rust. This may be necessary more frequently when subjected to salt air or road salt.
- Always check the lifting strap before each use. If any wear or fraying is noticed DO NOT USE THE LIFT! Contact the installer or dealer for repair. Failure to act may cause damage to the vehicle or severe injury!
- Hand control units should not be exposed to the weather. If the lift is mounted in the bed of a truck, remove the hand control between each use. Exposure to the elements may cause the unit to fail.

WARRANTY:

This lift is covered by a three year factory warranty on materials and workmanship. Contact your local dealer for more information or go to www.harmar.com for complete details.

AL200 / AL400 / AL055 Troubleshooting

PROBLEM: The lift will not operate or operates slowly.

Possible Causes:

Bad Electrical Connections —Verify that both connections at the battery are clean and have good surface area contact at both terminals of the battery. Inspect the full length of the wiring harness to be sure the insulation of the wire has not caused a short to the vehicle frame.

If the lift does not have good electrical connections, the motor will not run under full power and will affect the lifting capacity and the speed in which it operates. This can be tested by attaching a test harness to a fully charged shop battery, that is not on a vehicle, and try running the lift.

PROBLEM: Intermittent power to the lift. The lift will operate for a short period of time and quit. At a later time it will start working again.

Possible Causes:

Circuit Breaker—Although the breaker resets itself automatically, it may be malfunctioning and need to be replaced. Check for power at the lift with a test lamp.

Bad Electrical Connections —Verify that both connections at the battery are clean and have good surface area contact at both terminals of the battery. Inspect the full length of the wiring harness to be sure the insulation of the wire has not caused a short to the vehicle frame.

If the lift does not have good electrical connections, the motor will not run under full power and will affect the lifting capacity and the speed in which it operates. This can be tested by attaching a test harness to a fully charged shop battery, that is not on a vehicle, and try running the lift.

Hand Control—Test by bypassing the hand control. Do this for only a second or two. The lift, vehicle, scooter or chair may be damaged if continuous power is left supplied to the unit.

PROBLEM: Lifting arm is slow to swing in / out. (AL400 only)

Possible Causes:

Dirty Bushings—Clean and apply new grease to the white plastic bushing that is located in the Base.

Bad Electrical Connections —Verify that both connections at the battery are clean and have good surface area contact at both terminals of the battery. Inspect the full length of the wiring harness to be sure the insulation of the wire has not caused a short to the vehicle frame.

If the lift does not have good electrical connections, the motor will not run under full power and will affect the lifting capacity and the speed in which it operates. This can be tested by attaching a test harness to a fully charged shop battery, that is not on a vehicle, and try running the lift.

PROBLEM: The lifting strap operates in reverse.

Possible Causes:

The lifting strap was overextended. The lifting strap was lowered too far, causing the strap to wind around the spool backwards. Lower the strap until it unravels from the spool. Then, raise the strap in the proper direction.

PROBLEM: AL400 rotates in wrong direction when installed on the passenger side of the vehicle.

Possible Causes:

The lift is shipped from the factory to be mounted on the drivers side of the vehicle. To change the rotation for the passenger side remove the bolt located near the bottom of the post, rotate the motor 180 degrees and reinsert the bolt. Next, change the rotation of the motor located in the base by switching the wires on the motor to reverse the polarity.

PROBLEM: The scooter or chair tips to the front or back while it is being lifted.

Possible Causes:

The scooter or chair is being lifted off center. The docking device should center the lifting strap over the center of gravity which is generally around the center of the seat. Check to make sure the proper docking device is being used.

AL800 Vehicle Wiring Harness

Important Note: IMPROPER WIRING IS THE #1 CAUSE OF PROBLEMS IN THE OPERATION OF A VEHICLE LIFT. FOLLOW THE WIRING INSTRUCTIONS CAREFULLY

Located in the hardware package is the vehicle wiring harness. The harness is manufactured to, and complies with the SAE J1128 requirements. The wire harness is approximately 23 ft. long and will accommodate most vehicles.

Unwind the harness and lay it flat. One end of the harness has a black plug. This is the lift end of the harness and goes to the back of the vehicle.

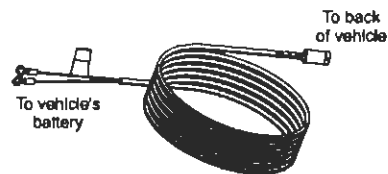

Begin routing the wiring harness at the vehicle battery. Attach the black wire to the negative terminal on the battery. Do not attach the red wire yet.

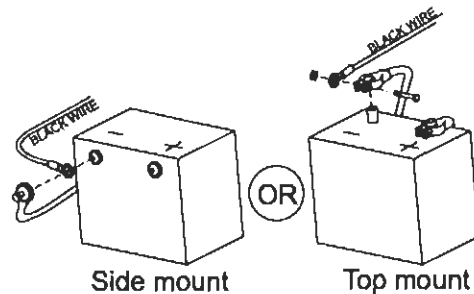

Run the wiring harness under or when possible through the vehicle, back to the cab wall. Always locate the wiring harness where it can not be snagged by road debris and away from the vehicles gas tank.

If the harness is too long for the vehicle, coil the excess wire and secure it to the vehicle frame with the supplied tie wraps. Do not cut or shorten the harness.

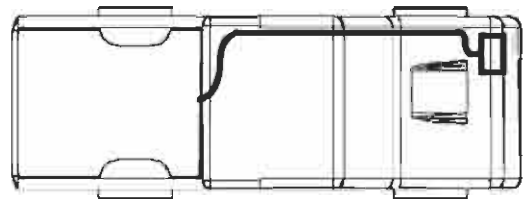

Attach the red wire to the positive terminal on the battery.

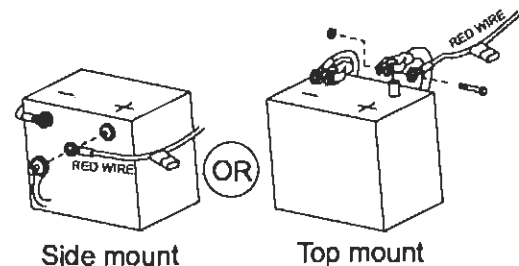

Important Reminder: Never attempt to attach the wire harness to a secondary power source, The lift requires direct connection to the battery.

Caution: When the installation requires the wiring harness be run on the underside of a vehicle, route the harness away from the exhaust system, brake lines, fuel lines, gas tank, pinch points, and sharp edges. Locate the wiring harness where it can not be snagged by road debris.

Manufactures Recommendation: Schedule a routine maintenance visit with the end user. Harmar recommends the lift be greased in the applicable areas, and the wire harness connections be checked for corrosion, and/or decay, as such conditions are normal due to environmental changes.

AL800 Wiring

In order for the Hand Controller to be accessible to the operator from inside the truck, a 5/8" hole must be drilled through the truck bed, and rear cab wall.

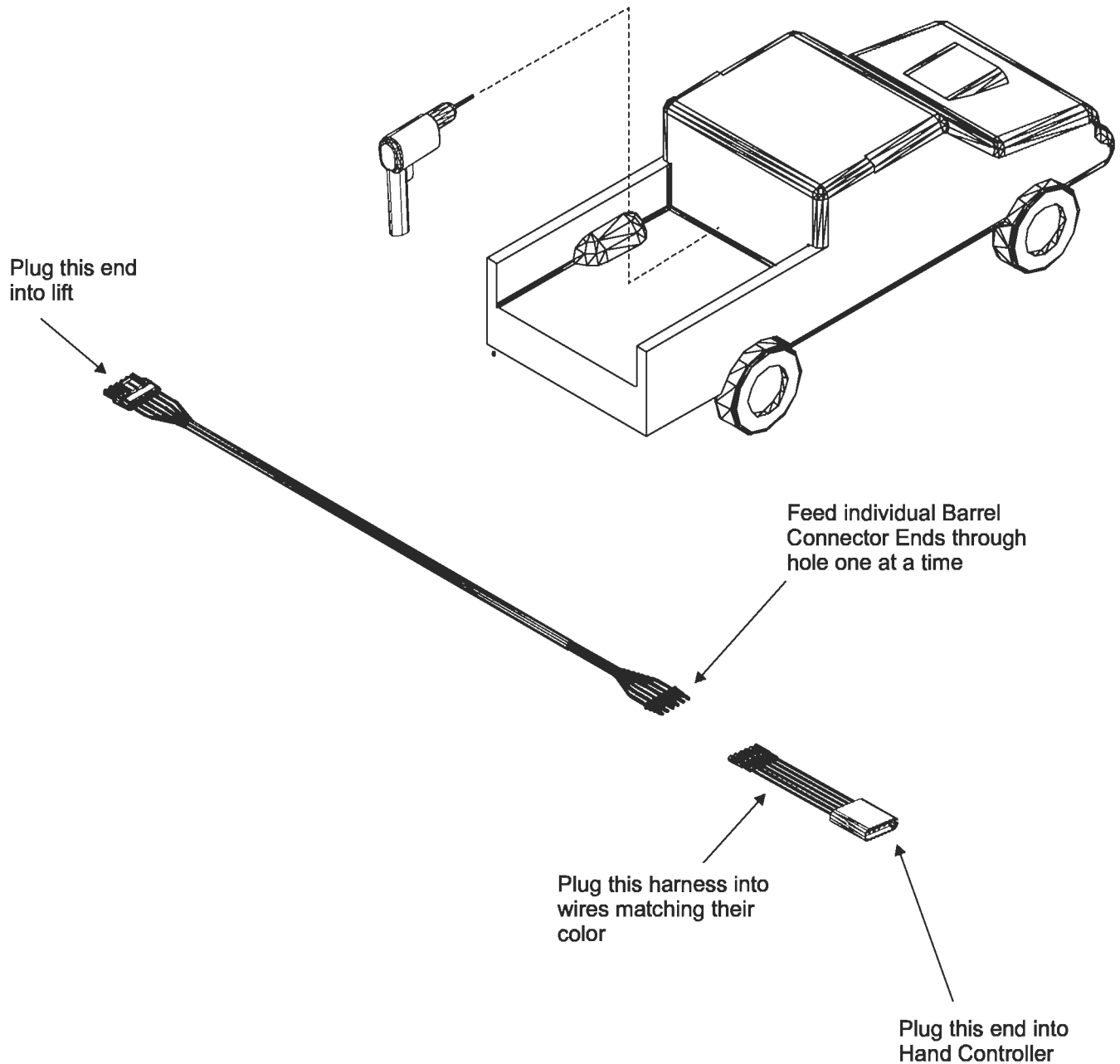

AL800 Installation

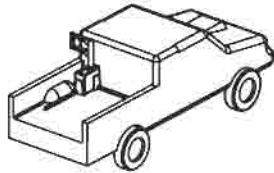

DRIVER SIDE INSTALLATION

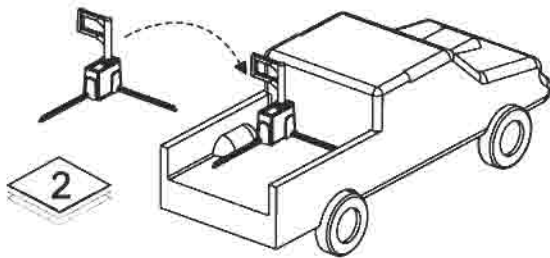
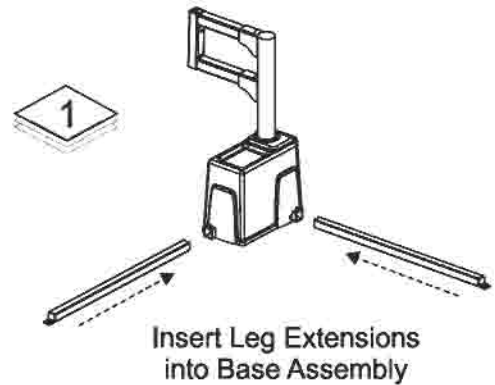

2

Place base in truck bed
and test fit
DO NOT DRILL YET

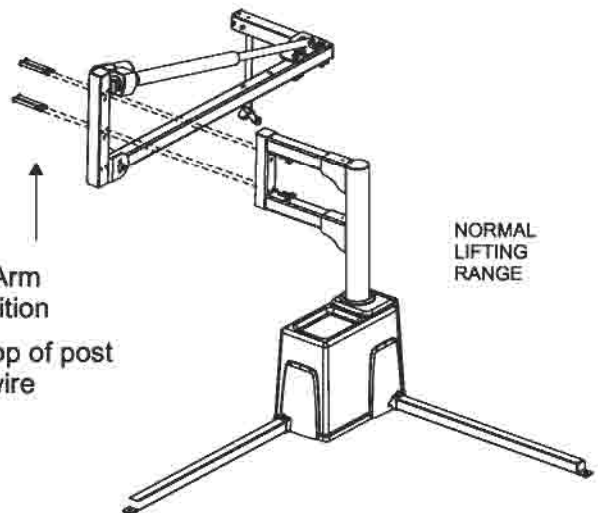
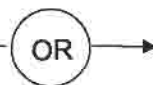
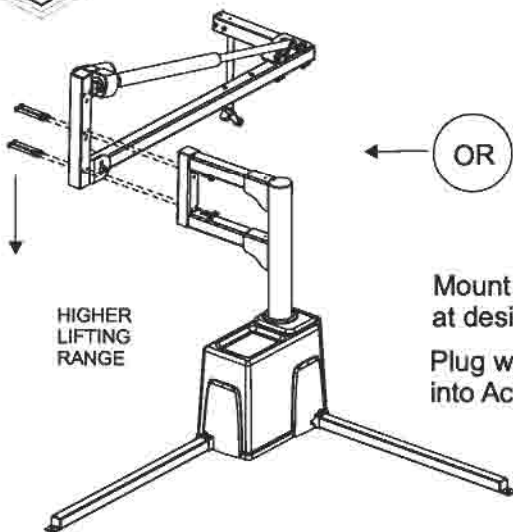
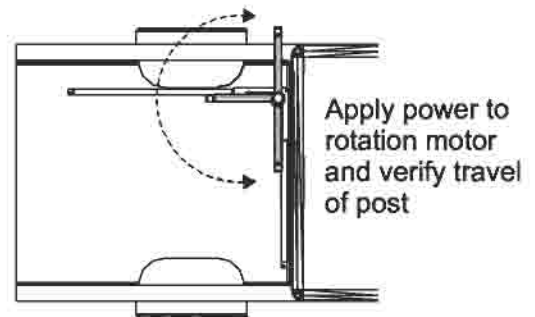

OR

Mount Lifting Arm
at desired position
Plug wire on top of post
into Actuator wire

Before drilling, it is recommended to connect power to the lift, and run the lift through its motions. Measure the distance required for the chair or scooter to clear to truck bed side wall, and reach the ground. Many reach options are available by re-orientating the Strap, Strap Mount, and Lifting Arm.

AL800 Installation

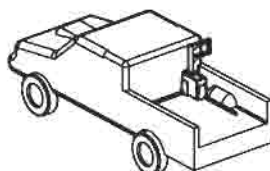
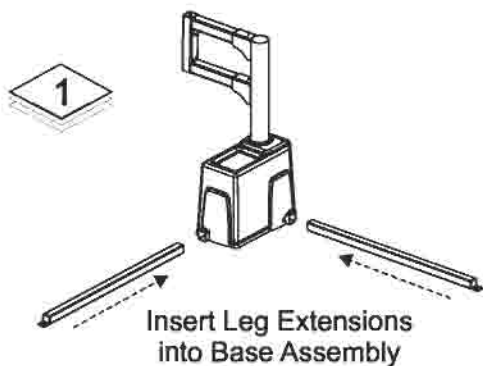

PASSENGER SIDE INSTALLATION

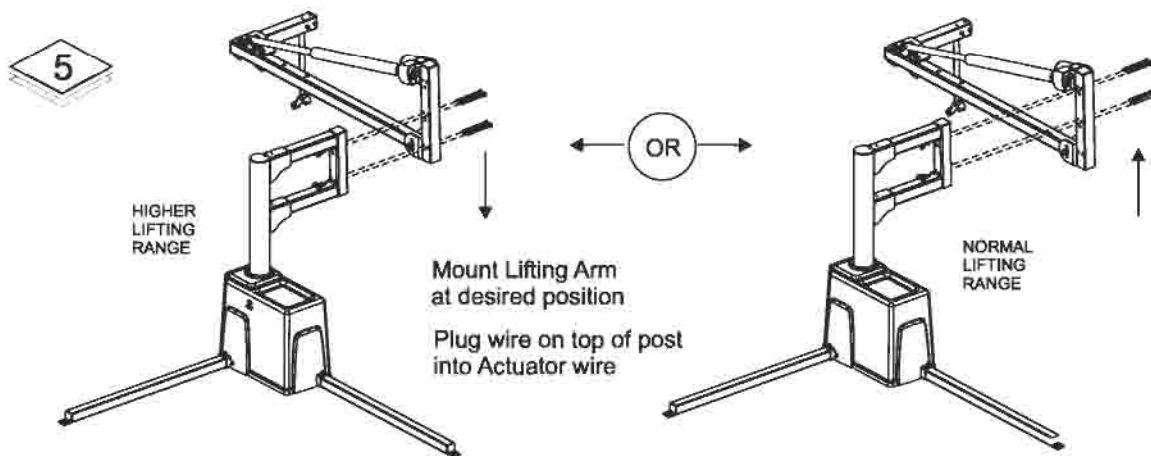
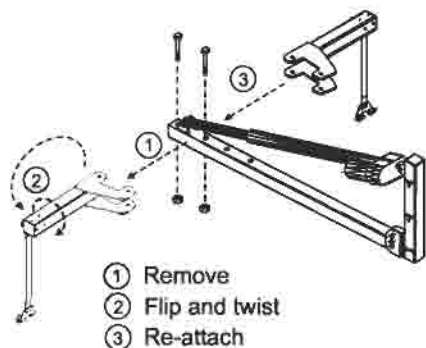
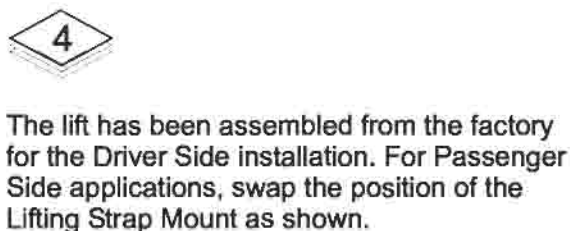
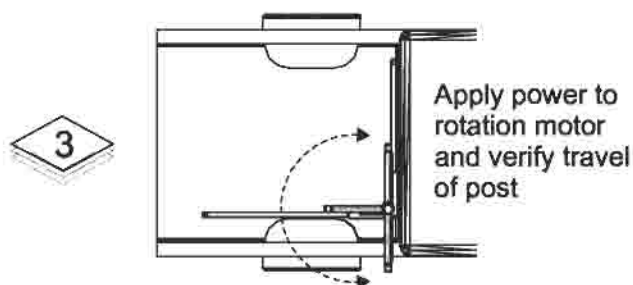
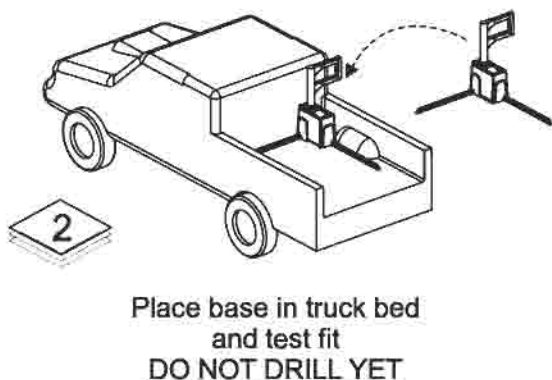

Before drilling, it is recommended to connect power to the lift, and run the lift through its motions. Measure the distance required for the chair or scooter to clear to truck bed side wall, and reach the ground. Many reach options are available by re-orientating the Strap, Strap Mount, and Lifting Arm.

AL800 Installation

Lifting height can be adjusted by changing the way the Strap is mounted. This is helpful when extra clearance is needed to lift the chair or scooter over the truck bed wall. If needed, simply unscrew the two bolts, arrange to one of the configurations shown, and re-attach.

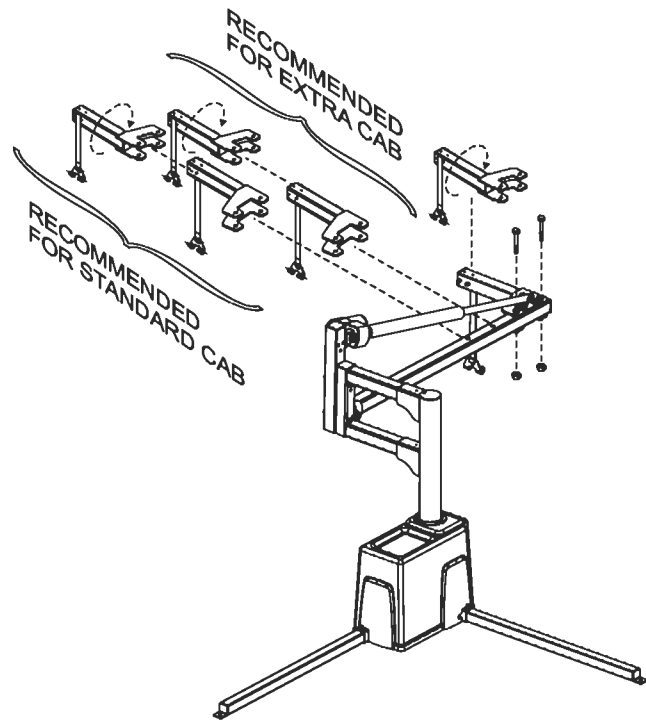
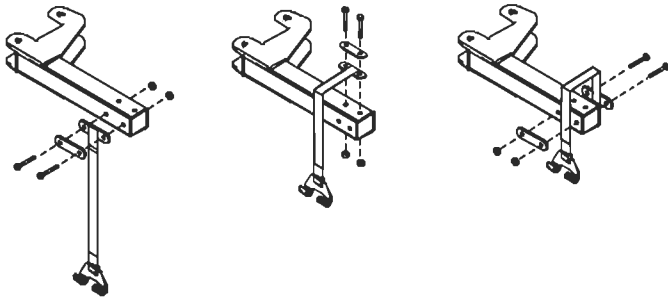

Several reach options are available with the removal and re-attachment of the lifting strap mount.

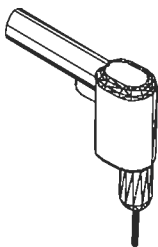

Caution! BEFORE drilling inspect under side of truck bed. Avoid the vehicle wiring, fuel lines, fuel tanks, spare tires, etc. when drilling.

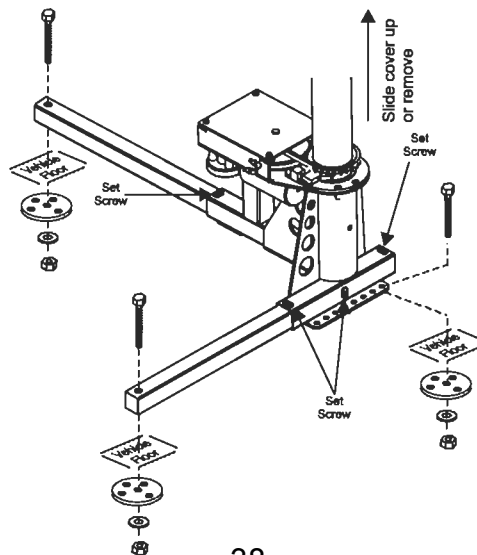

Once adjustments have been made, and confidence in range of motion has been gained, drill into truck bed, and secure base using provided hardware.

AL800 Operation

Operational Guidelines:

- Inspect the Lifting Strap prior to each use. Contact your distributor if it shows signs of wear or fraying.
- Do not operate this lift until you dealer has satisfactorily instructed you in the proper operation of this lift.
- Always make sure the vehicle's parking brake is firmly set before operation.
- Keep hands and feet from under the scooter or power chair as it is being lifted.

Instructions start from the empty stowed position.

- 1) Press the "UP" button on the hand controller. Continue to lift the arm until its strap hook will clear the truck bed wall.
- 2) Press the "OUT" button until the arm has rotated parallel with the truck.
- 3) Press the "DOWN" button until the strap has lowered enough to be fastened to the docking device on the chair.
- 4) Clip strap hook to chair.
- 5) Press the "UP" button and continue to lift until the bottom of the chair will clear the truck bed wall.
- 6) Press the "IN" button, watching closely that the chair will clear the wall.
- 7) Once the chair is the desired side to side location in the bed, press the "DOWN" button to lower.

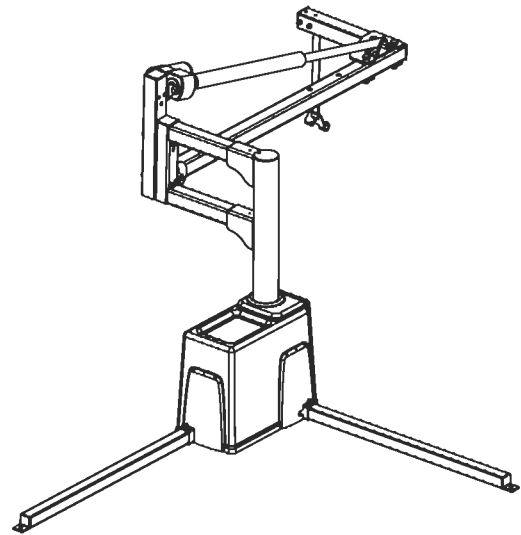

Once the chair is resting in the bed, press "UP" momentarily. This will tighten the strap, and will help to stabilize the chair during travel. DO NOT allow the chair wheels to leave the truck bed, most of the weight should remain on the bed.

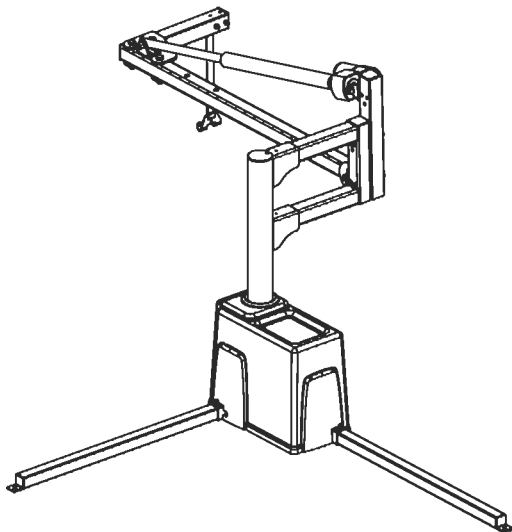

Instructions for the loaded stowed position.

- 1) Verify that the strap hook is still connected to the chair's docking device.
- 2) Press the "UP" button and continue lifting until the chair's wheels will clear the truck bed wall.
- 3) Press the "OUT" button, and continue until the arm has rotated parallel with the truck.
- 4) Press the "DOWN" button until the chair reaches the ground.
- 5) Unhook the strap hook from the docking device.
- 6) Press the "UP" button until the strap hook will clear the truck bed wall.
- 7) Press the "IN" button, watching that the strap hook will clear the bed wall.
- 8) Press the "DOWN" button, until the desired stowed position is obtained.

AL800

Safety and Maintenance

SAFETY:

- **Caution:** Do not operate this lift until your dealer has satisfactorily instructed you in the proper operation of the lift.
- Your Harmar Inside Lift has been engineered and designed for years of trouble free use. Although, with everyday use, some parts may become loose or worn. **IMPORTANT!** Check regularly for any worn, loose or damaged parts of your lift. **If anything is observed, DO NOT USE THE LIFT!** Contact your dealer or installer of the lift for repairs to be made. **Failure to act may cause severe injury!**
- Your Harmar Inside Lift should only be used for the loading and unloading of scooters and power wheelchairs for which it is designed. **DO NOT** add to or modify any part of the lift system without first contacting the manufacturer of the lift. Any modifications may void any warranties as well as effect the structural integrity of the lift.
- **ALWAYS CHECK THE LIFTING STRAP BEFORE EACH USE FOR DAMAGE OR WEAR.**
- Always make sure the vehicle's parking brake is firmly set before operating the lift.
- **Caution:** Insure that the Lifting Strap is secure and taught and that it points straight down before lifting of the scooter or power chair. Failure to do so could result in the scooter or chair swinging toward the operator of the vehicle.
- **Caution:** When using the lift, keep your hands and feet from under the scooter or power chair as it is being loaded or unloaded.
- **Caution:** Stop lifting before the Strap Hook contacts the Strap Roller mounted on the Lifting Arm. Contact will result in damage to the lift. A properly adjusted and operated lift will avoid this.
- **Caution:** Insure that the scooter or chair is firmly sitting on the floor of the vehicle and not suspended by the lift. If the scooter or power chair is not firmly on the floor of the vehicle, it may move during transportation and cause damage to the lift, scooter or power chair, vehicle, or passengers.

MAINTENANCE:

The Harmar Inside Lift has been designed to be as trouble free as possible for the owner. But, as with any mechanical device, regular care should be given while owning and using this device.

Maintenance is no exception.

- We recommend that dealers should schedule a preventative maintenance inspection at least once a year on motors, lift frame, wiring harness and all moving parts of the lift.
- Check for paint chips and touch up any bare metal with a good gloss black enamel or lacquer to inhibit rust. This may be necessary more frequently when subjected to salt air or road salt.
- Always check the lifting strap before each use. If any wear or fraying is noticed **DO NOT USE THE LIFT!** Contact the installer or dealer for repair. Failure to act may cause damage to the vehicle or severe injury!
- Hand control units should not be exposed to the weather. If the lift is mounted in the bed of a truck, remove the hand control between each use. Exposure to the elements may cause the unit to fail.

WARRANTY:

This lift is covered by a three year factory warranty on materials and workmanship. Contact your local dealer for more information or go to www.harmar.com for complete details.

AL800 Troubleshooting

PROBLEM: The lift will not operate or operates slowly.

Possible Causes:

Bad Ground—Verify the ground end of the Vehicle Harness is touching the vehicle frame in an area that is free of paint and corrosion. If the lift does not have a good ground, the motor will not run under full power and will affect the lifting capacity and the speed in which it operates. This can be tested by attaching a test harness to a fully charged shop battery that is not on a vehicle and running the lift.

Battery—Check to see if the battery needs to be replaced or if the terminals are corroded. Clean the terminals if any corrosion is present. 12 volts should be present at the lifting or rotational motors from the vehicles battery. This can be tested with a voltage meter.

PROBLEM: Intermittent power to the lift. The lift will operate for a short period of time and quit. At a later time it will start working again.

Possible Causes:

Circuit Breaker—Although the breaker resets itself automatically, it may be malfunctioning and need to be replaced. Check for power at the lift with a test lamp.

Bad Ground—Verify the ground end of the Vehicle Harness is touching the vehicle frame in an area that is free of paint and corrosion. If the lift does not have a good ground, the motor will not run under full power and will affect the lifting capacity and the speed in which it operates. An intermittent ground will cause the lift to lose power. This can be tested by attaching a test harness to a fully charged shop battery that is not on a vehicle and running the lift.

Hand Control—Test by bypassing the hand control. Do this for only a second or two. The lift, vehicle, scooter or chair may be damaged if continuous power is left supplied to the unit.

PROBLEM: Lifting arm is slow to swing in / out.

Possible Causes:

Dirty Bushings—Clean and apply new grease to the white plastic bushing that is located in the Base.

Bad Ground—Verify the ground end of the Vehicle Harness is touching the vehicle frame in an area that is free of paint and corrosion. If the lift does not have a good ground, the motor will not run under full power and will affect the lifting capacity and the speed in which it operates. This can be tested by attaching a test harness to a fully charged shop battery that is not on a vehicle and running the lift.

PROBLEM: AL800 rotates in wrong direction when installed on the passenger side of the vehicle.

Possible Causes:

The lift is shipped from the factory to be mounted on the drivers side of the vehicle. To change the rotation for the passenger side remove the bolt located near the bottom of the post, rotate the motor 180 degrees and reinsert the bolt. Next, change the rotation of the motor located in the base by switching the wires on the motor to reverse the polarity.

PROBLEM: The scooter or chair tips to the front or back while it is being lifted.

Possible Causes:

The scooter or chair is being lifted off center. The docking device should center the lifting strap over the center of gravity which is generally around the center of the seat. Check to make sure the proper docking device is being used.

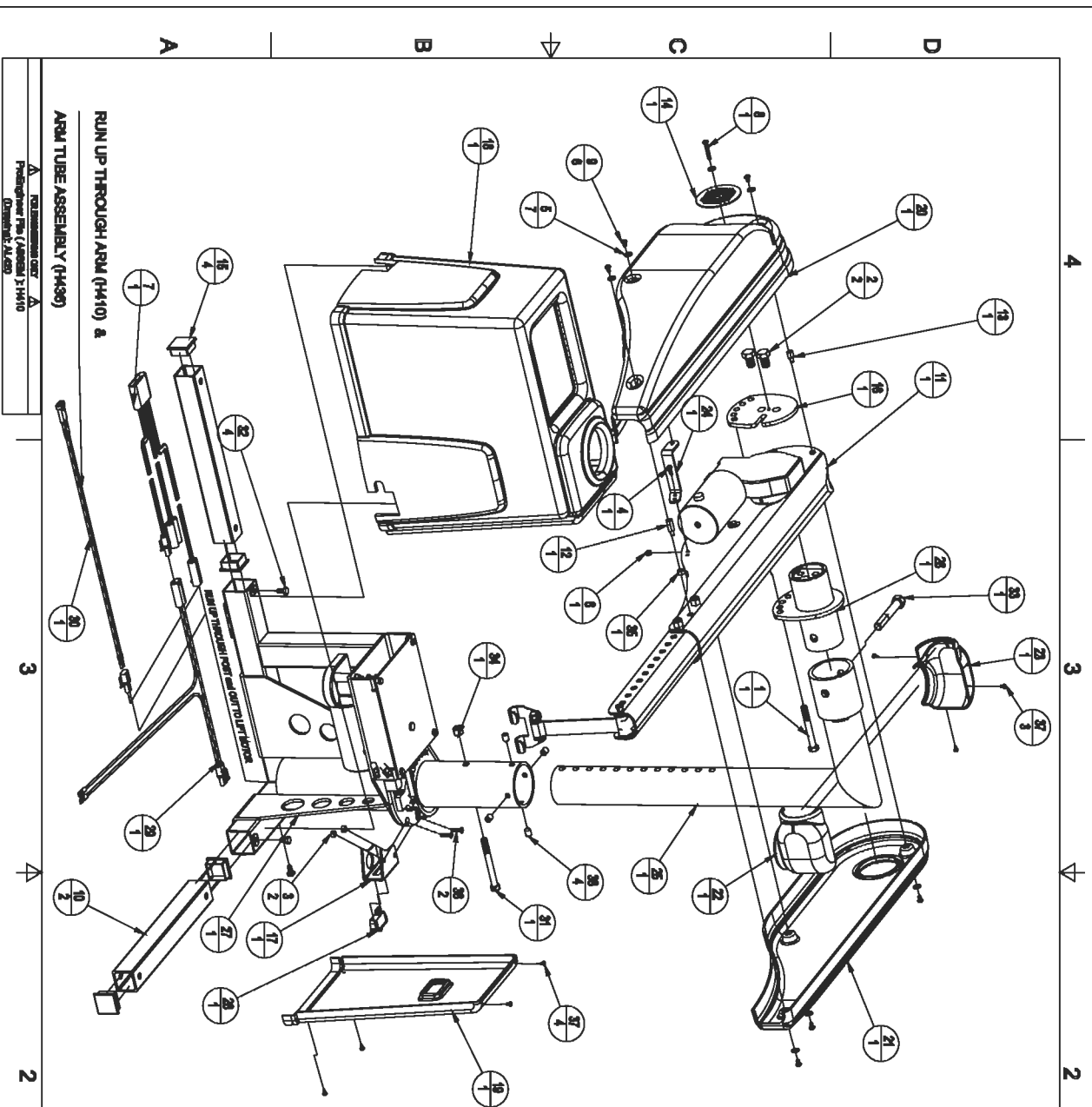

ITEM	QTY	PART NO.	DESCRIPTION
1	1	H420	38-10 x 3/4"
2	2	H420	1/2-13 x 3/4"
3	2	NUT	10-32 Nylon Nut
4	1	PH-110	8-32 x 1/2 Phillips Flat Head
5	7	WASHER	8/16 Flat Washer #10, 7/8" ID, 1/2" OD, Zinc
6	1	6-35NUT	6-32 Nylon Nut
7	1	AL420H	AL420 WIRING HARNESS
8	1	H420	10-24 x 1-1/4" Nylon Head Socket
9	8	H420	10-32 x 3/8"
10	2	H420	LEGS EXTENSION
11	1	H410	LIFTING ARM ASSEMBLY
12	1	H420	Hex Standoff 10-32 - 3/4"
13	1	H420	Hex Standoff 10-32 - 3/8"
14	1	H420	COVER PLATE
15	4	H420	Cap for 1.5sq x 1.2sq Tube
16	1	H420	TILT BRACKET
17	1	H420	AL420 ON/OFF SWITCH BRKT
18	1	H4212	AL420 PLASTIC BASE COVER
19	1	H4210	AL420 PLASTIC DOOR (WITH CUT OUT)
20	1	H4214	AL420H10 TOP LEFT COVER
21	1	H4216	TOP RIGHT COVER
22	1	H4218	AL420 90 DEGREE COVER (LEFT)
23	1	H4217	AL420 90 DEGREE COVER (RIGHT)
24	1	H4219	COVER ATNCH BRACKET
25	1	H425	AL420 OFFSET POST
26	1	H425	AL420 ARM TUBE ASSEMBLY
27	1	H425	BASE ASSEMBLY
28	1	H425	POWER SWITCH
29	1	H425	AL420 ON/OFF SWITCH WIRE
30	1	H425	AL420H10Z10Z20 POST/ARM SHORT WIRE
31	1	H425	38-10 x 3/4"
32	4	H425	1/2-13 x 1/2"
33	1	H425	14-20 x 1/2"
34	1	NUT	38-10 Nylon Nut
35	1	NUT	1/4-20 NUT
36	1	PH-110	10-32 x 3/4" Phillips Flat Head
37	7	PH-110	attnel metal screw Black Oxide Hex. 8-32" length
38	4	SETSCREW	38-10 x 1/2" Allen Head

ASSEMBLY PARTS

ITEM NO. AL420

DESCRIPTION Fully Powered Inside Lift

DATE

REV. 1

REV. 2

REV. 3

REV. 4

REV. 5

REV. 6

REV. 7

REV. 8

REV. 9

REV. 10

REV. 11

REV. 12

REV. 13

REV. 14

REV. 15

REV. 16

REV. 17

REV. 18

REV. 19

REV. 20

REV. 21

REV. 22

REV. 23

REV. 24

REV. 25

REV. 26

REV. 27

REV. 28

REV. 29

REV. 30

REV. 31

REV. 32

REV. 33

REV. 34

REV. 35

REV. 36

REV. 37

REV. 38

REV. 39

REV. 40

REV. 41

REV. 42

REV. 43

REV. 44

REV. 45

REV. 46

REV. 47

REV. 48

REV. 49

REV. 50

REV. 51

REV. 52

REV. 53

REV. 54

REV. 55

REV. 56

REV. 57

REV. 58

REV. 59

REV. 60

REV. 61

REV. 62

REV. 63

REV. 64

REV. 65

REV. 66

REV. 67

REV. 68

REV. 69

REV. 70

REV. 71

REV. 72

REV. 73

REV. 74

REV. 75

REV. 76

REV. 77

REV. 78

REV. 79

REV. 80

REV. 81

REV. 82

REV. 83

REV. 84

REV. 85

REV. 86

REV. 87

REV. 88

REV. 89

REV. 90

REV. 91

REV. 92

REV. 93

REV. 94

REV. 95

REV. 96

REV. 97

REV. 98

REV. 99

REV. 100

REV. 101

REV. 102

REV. 103

REV. 104

REV. 105

REV. 106

REV. 107

REV. 108

REV. 109

REV. 110

REV. 111

REV. 112

REV. 113

REV. 114

REV. 115

REV. 116

REV. 117

REV. 118

REV. 119

REV. 120

REV. 121

REV. 122

REV. 123

REV. 124

REV. 125

REV. 126

REV. 127

REV. 128

REV. 129

REV. 130

REV. 131

REV. 132

REV. 133

REV. 134

REV. 135

REV. 136

REV. 137

REV. 138

REV. 139

REV. 140

REV. 141

REV. 142

REV. 143

REV. 144

REV. 145

REV. 146

REV. 147

REV. 148

REV. 149

REV. 150

REV. 151

REV. 152

REV. 153

REV. 154

REV. 155

REV. 156

REV. 157

REV. 158

REV. 159

REV. 160

REV. 161

REV. 162

REV. 163

REV. 164

REV. 165

REV. 166

REV. 167

REV. 168

REV. 169

REV. 170

REV. 171

REV. 172

REV. 173

REV. 174

REV. 175

REV. 176

REV. 177

REV. 178

REV. 179

REV. 180

REV. 181

REV. 182

REV. 183

REV. 184

REV. 185

REV. 186

REV. 187

REV. 188

REV. 189

REV. 190

REV. 191

REV. 192

REV. 193

REV. 194

REV. 195

REV. 196

REV. 197

REV. 198

REV. 199

REV. 200

REV. 201

REV. 202

REV. 203

REV. 204

REV. 205

REV. 206

REV. 207

REV. 208

REV. 209

REV. 210

REV. 211

REV. 212

REV. 213

REV. 214

REV. 215

REV. 216

REV. 217

REV. 218

REV. 219

REV. 220

REV. 221

REV. 222

REV. 223

REV. 224

REV. 225

REV. 226

REV. 227

REV. 228

REV. 229

REV. 230

REV. 231

REV. 232

REV. 233

REV. 234

REV. 235

REV. 236

REV. 237

REV. 238

REV. 239

REV. 240

REV. 241

REV. 242

REV. 243

REV. 244

REV. 245

REV. 246

REV. 247

REV. 248

REV. 249

REV. 250

REV. 251

REV. 252

REV. 253

REV. 254

REV. 255

REV. 256

REV. 257

REV. 258

REV. 259

REV. 260

REV. 261

REV. 262

REV. 263

REV. 264

REV. 265

REV. 266

REV. 267

REV. 268

REV. 269

REV. 270

REV. 271

REV. 272

REV. 273

REV. 274

REV. 275

REV. 276

REV. 277

REV. 278

REV. 279

REV. 280

REV. 281

REV. 282

REV. 283

REV. 284

REV. 285

REV. 286

REV. 287

REV. 288

REV. 289

REV. 290

REV. 291

REV. 292

REV. 293

REV. 294

REV. 295

REV. 296

REV. 297

REV. 298

REV. 299

REV. 300

REV. 301

REV. 302

REV. 303

REV. 304

REV. 305

REV. 306

REV. 307

REV. 308

REV. 309

REV. 310

REV. 311

REV. 312

REV. 313

REV. 314

REV. 315

REV. 316

REV. 317

REV. 318

REV. 319

REV. 320

REV. 321

REV. 322

REV. 323

REV. 324

REV. 325

REV. 326

REV. 327

REV. 328

REV. 329

REV. 330

REV. 331

REV. 332

REV. 333

REV. 334

REV. 335

REV. 336

REV. 337

REV. 338

REV. 339

REV. 340

REV. 341

REV. 342

REV. 343

REV. 344

REV. 345

REV. 346

REV. 347

REV. 348

REV. 349

REV. 350

REV. 351

REV. 352

REV. 353

REV. 354

REV. 355

REV. 356

REV. 357

REV. 358

REV. 359

REV. 360

REV. 361

REV. 362

REV. 363

REV. 364

REV. 365

REV. 366

REV. 367

REV. 368

REV. 369

REV. 370

REV. 371

REV. 372

REV. 373

REV. 374

REV. 375

REV. 376

REV. 377

REV. 378

REV. 379

REV. 380

REV. 381

REV. 382

REV. 383

REV. 384

REV. 385

REV. 386

REV. 387

REV. 388

REV. 389

REV. 390

REV. 391

REV. 392

REV. 393

REV. 394

REV. 395

REV. 396

REV. 397

REV. 398

REV. 399

REV. 400

REV. 401

REV. 402

REV. 403

REV. 404

REV. 405

REV. 406

REV. 407

REV. 408

REV. 409

REV. 410

REV. 411

REV. 412

REV. 413

REV. 414

REV. 415

REV. 416

REV. 417

REV. 418

REV. 419

REV. 420

REV. 421

REV. 422

REV. 423

REV. 424

REV. 425

REV. 426

REV. 427

REV. 428

REV. 429

REV. 430

REV. 431

REV. 432

REV. 433

REV. 434

REV. 435

REV. 436

REV. 437

REV. 438

REV. 439

REV. 440

REV. 441

REV. 442

REV. 443

REV. 444

REV. 445

REV. 446

REV. 447

REV. 448

REV. 449

REV. 450

REV. 451

REV. 452

REV. 453

REV. 454

REV. 455

REV. 456

REV. 457

REV. 458

REV. 459

REV. 460

REV. 461

REV. 462

REV. 463

REV. 464

REV. 465

REV. 466

REV. 467

REV. 468

REV. 469

REV. 470

REV. 471

REV. 472

REV. 473

REV. 474

REV. 475

REV. 476

REV. 477

REV. 478

REV. 479

REV. 480

REV. 481

REV. 482

REV. 483

REV. 484

REV. 485

REV. 486

REV. 487

REV. 488

REV. 489

REV. 490

REV. 491

REV. 492

REV. 493

REV. 494

REV. 495

REV. 496

REV. 497

REV. 498

REV. 499

REV. 500

REV. 501

REV. 502

REV. 503

REV. 504

REV. 505

REV. 506

REV. 507

REV. 508

REV. 509

REV. 510

REV. 511

REV. 512

REV. 513

REV. 514

REV. 515

REV. 516

REV. 517

REV. 518

REV. 519

REV. 520

REV. 521

REV. 522

REV. 523

REV. 524

REV. 525

REV. 526

REV. 527

REV. 528

REV. 529

REV. 530

REV. 531

REV. 532

REV. 533

REV. 534

REV. 535

REV. 536

REV. 537

REV. 538

REV. 539

REV. 540

REV. 541

REV. 542

REV. 543

REV. 544

REV. 545

REV. 546

REV. 547

REV. 548

REV. 549

REV. 550

REV. 551

REV. 552

REV. 553

REV. 554

REV. 555

REV. 556

REV. 557

REV. 558

REV. 559

REV. 560

REV. 561

REV. 562

REV. 563

REV. 564

REV. 565

REV. 566

REV. 567

REV. 568

REV. 569

REV. 570

REV. 571

REV. 572

REV. 573

REV. 574

REV. 575

REV. 576

REV. 577

REV. 578

REV. 579

REV. 580

REV. 581

REV. 582

REV. 583

REV. 584

REV. 585

REV. 586

REV. 587

REV. 588

REV. 589

REV. 590

REV. 591

REV. 592

REV. 593

REV. 594

REV. 595

REV. 596

REV. 597

REV. 598

REV. 599

REV. 600

REV. 601

REV. 602

REV. 603

REV. 604

REV. 605

REV. 606

REV. 607

REV. 608

REV. 609

REV. 610

REV. 611

REV. 612

REV. 613

REV. 614

REV. 615

REV. 616

REV. 617

REV. 618

REV. 619

REV. 620

REV. 621

REV. 622

REV. 623

REV. 624

REV. 625

REV. 626

REV. 627

REV. 628

REV. 629

REV. 630

REV. 631

REV. 632

REV. 633

REV. 634

REV. 635

REV. 636

REV. 637

REV. 638

REV. 639

REV. 640

REV. 641

REV. 642

REV. 643

REV. 644

REV. 645

REV. 646

REV. 647

REV. 648

REV. 649

REV. 650

REV. 651

REV. 652

REV. 653

REV. 654

REV. 655

REV. 656

REV. 657

REV. 658

REV. 659

REV. 660

REV. 661

REV. 662

REV. 663

REV. 664

REV. 665

REV. 666

REV. 667

REV. 668

REV. 669

REV. 670

REV. 671

REV. 672

REV. 673

REV. 674

REV. 675

REV. 676

REV. 677

REV. 678

REV. 679

REV. 680

REV. 681

REV. 682

REV. 683

REV. 684

REV. 685

REV. 686

REV. 687

REV. 688

REV. 689

REV. 690

REV. 691

REV. 692

REV. 693

REV. 694

REV. 695

REV. 696

REV. 697

REV. 698

REV. 699

REV. 700

REV. 701

REV. 702

REV. 703

REV. 704

REV. 705

REV. 706

REV. 707

REV. 708

REV. 709

REV. 710

REV. 711

REV. 712

REV. 713

REV. 714

REV. 715

REV. 716

REV. 717

REV. 718

REV. 719

REV. 720

REV. 721

REV. 722

REV. 723

REV. 724

REV. 725

REV. 726

REV. 727

REV. 728

REV. 729

REV. 730

REV. 731

REV. 732

REV. 733

REV. 734

REV. 735

REV. 736

REV. 737

REV. 738

REV. 739

REV. 740

REV. 741

REV. 742

REV. 743

REV. 744

REV. 745

REV. 746

REV. 747

REV. 748

REV. 749

REV. 750

REV. 751

REV. 752

REV. 753

REV. 754

REV. 755

REV. 756

REV. 757

REV. 758

REV. 759

REV. 760

REV. 761

REV. 762

REV. 763

REV. 764

REV. 765

REV. 766

REV. 767

REV. 768

REV. 769

REV. 770

REV. 771

REV. 772

REV. 773

REV. 774

REV. 775

REV. 776

REV. 777

REV. 778

REV. 779

REV. 780

REV. 781

REV. 782

REV. 783

REV. 784

REV. 785

REV. 786

REV. 787

REV. 788

REV. 789

REV. 790

REV. 791

REV. 792

REV. 793

REV. 794

REV. 795

REV. 796

REV. 797

REV. 798

REV. 799

REV. 800

REV. 801

REV. 802

REV. 803

REV. 804

REV. 805

REV. 806

REV. 807

REV. 808

REV. 809

REV. 810

REV. 811

REV. 812

REV. 813

REV. 814

REV. 815

REV. 816

REV. 817

REV. 818

REV. 819

REV. 820

REV. 821

REV. 822

REV. 823

REV. 824

REV. 825

REV. 826

REV. 827

REV. 828

REV. 829

REV. 830

REV. 831

REV. 832

REV. 833

REV. 834

REV. 835

REV. 836

REV. 837

REV. 838

REV. 839

REV. 840

REV. 841

REV. 842

REV. 843

REV. 844

REV. 845

REV. 846

REV. 847

REV. 848

REV. 849

REV. 850

REV. 851

REV. 852

REV. 853

REV. 854

REV. 855

REV. 856

REV. 857

REV. 858

REV. 859

REV. 860

REV. 861

REV. 862

REV.

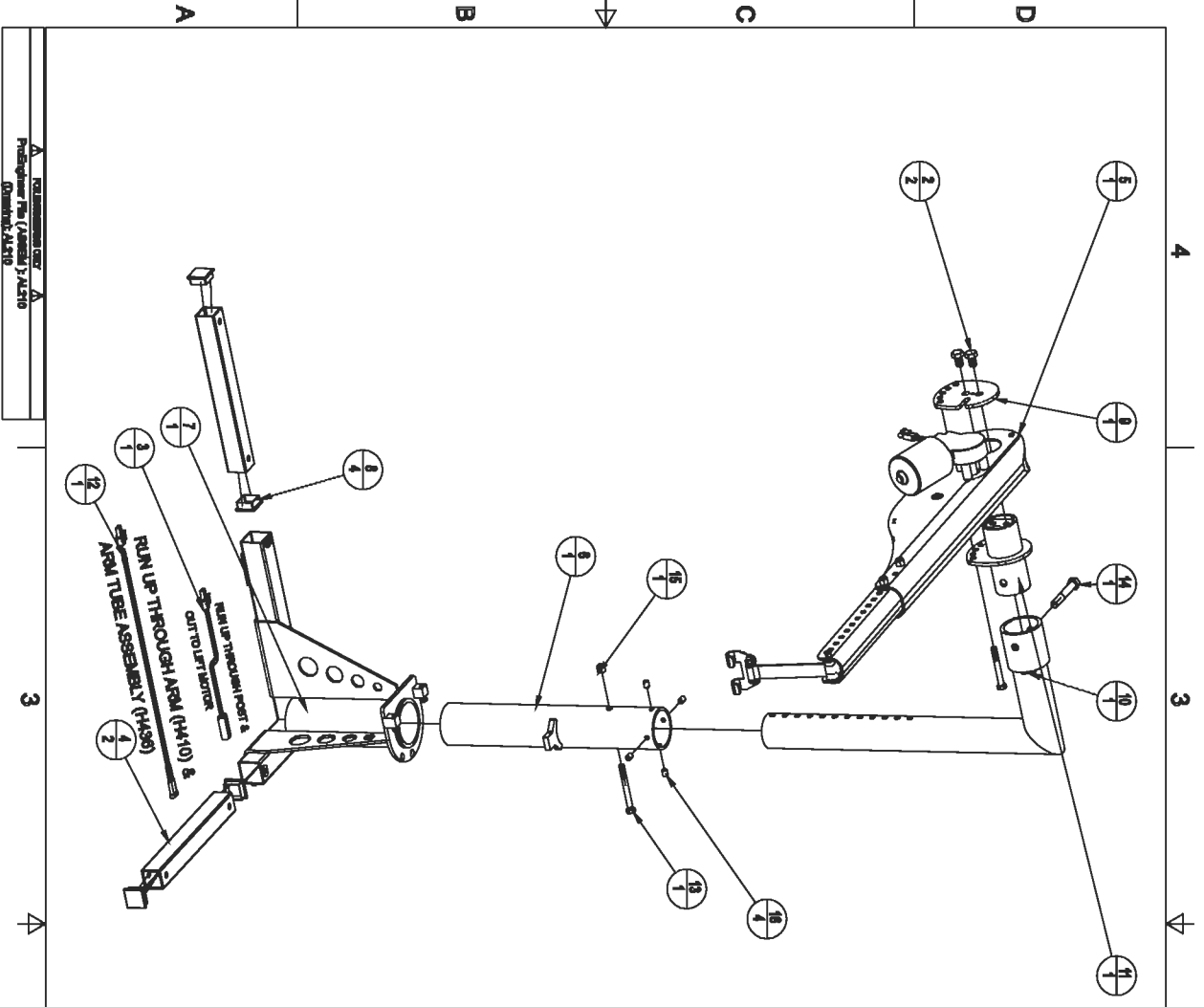

ASSEMBLY PARTS		
ITEM QTY	PART NO.	DESCRIPTION
1 1	HHCS	30-16 x 3.00"
2 2	HHCS	1/2-13 x 3.50"
3 1	AL40050	AL210 W/ing Hinges
4 2	H205	LEG EXTENSION
5 1	H210	LIFTING ARM ASSY
8 1	H245	AL210 OUTER TUBE ASSY
7 1	H291	AL210 BASE ASSY
8 4	H4005	CAP for 1.5sq x 1.25w Tube
9 1	H4200	TLT BRACKET
10 1	H405	AL210 OFFSET POST
11 1	H408	AL210 ARM TUBE ASSEMBLY
12 1	H4008	AL40008 PORTFURN SHORT WIRE
13 1	HHCS	30-16 x 3.5"
14 1	HHCS	1/2-13 x 3.25"
15 1	NUT	30-16 Nyloc Nut
18 4	SETSCREW	30-16 x 1/2" diam head

UNIVERSAL INSIDE LIFT

AL210

DATE: 08/27/2018

SCALE: 1:1

QUANTITY: 2 OF 2

DO NOT SCALE DIMENSIONS

CONVENTIONAL DIMENSIONS NOT TO BE GIVEN OR USED WITHOUT WRITTEN CONSENT

UNIVERSAL LIFT

AL210

DATE: 08/27/2018

SCALE: 1:1

QUANTITY: 2 OF 2

AL210

UNIVERSAL INSIDE LIFT

DATE: 08/27/2018

SCALE: 1:1

QUANTITY: 2 OF 2

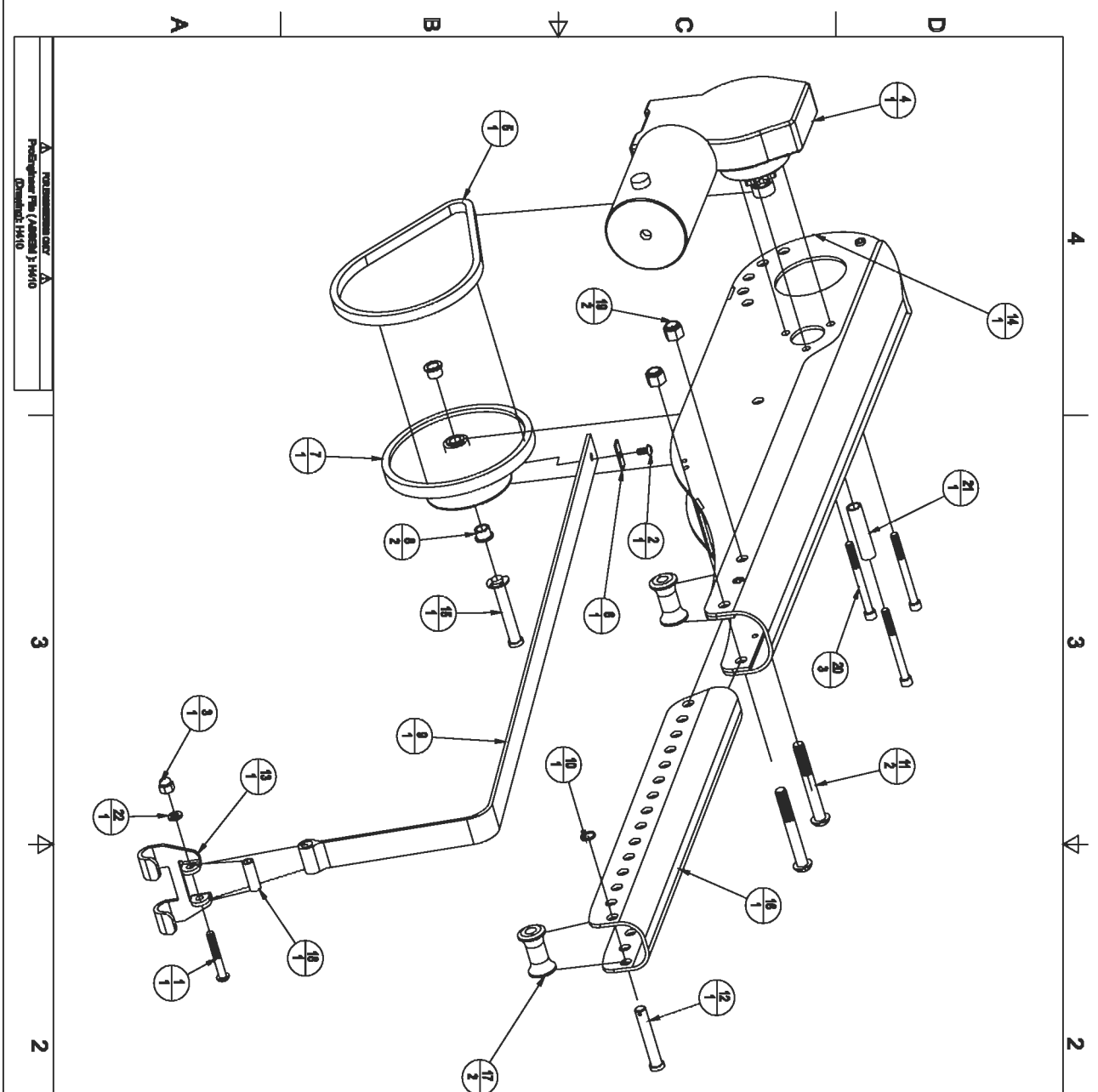

ASSEMBLY PARTS		1
ITEM QTY	PART NO.	DESCRIPTION
1	BHCS	1/4-20 x 1.75 Button Head Cap
2	BHCS	10-32 x 3/8" Button Head
3	ACORN NUT	1/4-20 Acorn Nut
4	AL21011	LIFTING MOTOR
5	AL21020	SPOOL CHAIN, 80 LINKS
6	AL21025	STRAP TAB
7	AL2114	SPOOL
8	AL21410	FLANGE BUSHING BRZ 38X1/2X3/8
9	AL21077	LIFTING STRAP
10	AL21081-14	BRIT RING
11	BHCS	3/8-16 x 3.07" Button Head Cap
12	CLEVIS PIN	3/8 x 2.25 (2.016 inside)
13	H21072	DETACHABLE HOOK
14	H4100	LIFTING ARM (head only)
15	H41020	CLEVIS 3/8 x 2.5" (2.343 inside)
16	H42040	AL220 INNER ARM
17	H42050	STRAP ROLLER
18	H42065	STRAP HOOK ROLL SLERVE
19	NUT	3/8-16 Nyloc Nut
20	SHCS	1/4-20 x 2.75" Socket Head Cap
21	TU1-050-065AL-2-00	ALUMINUM SPACER
22	WASHER	1/4" SPLIT LOCK WASHER

<p>OPERATIONAL INFORMATION OPERATE THIS LIFTING ARM ONLY WITHOUT THE LIFTING COLUMN WITHOUT THE LIFTING COLUMN</p>		<p>DO NOT SCALE DIMENSIONS</p>	
<p>LINKAGE COUNTERWEIGHTS (EXCEPTED) TO BE USED WITH THE LIFTING COLUMN ONLY</p>	<p>DRWG NO. H4110</p>	<p>MATERIAL FR3001</p>	<p>DATE</p>
<p>DESCRIPTION LIFTING ARM ASSY</p>	<p>SCALE: 1:1</p>	<p>DESIGN BY GMB/B</p>	<p>DATE</p>

NO DIMENSIONS ON
Pictograph File (Assembled) H4110
Drawing: H4110

A POLYMERIZATION UNIT
 Pre-assembled (Assembled) Ratio
 Diameter 12510

3

2

1

4

3

2

1

4

3

2

1

4

3

2

1

4

3

2

1

4

3

2

1

4

3

2

1

4

3

2

1

4

3

2

1

4

3

2

1

4

3

2

1

4

3

2

1

4

3

2

1

4

3

2

1

4

3

2

1

4

3

2

1

4

3

2

1

4

3

2

1

4

3

2

1

4

3

2

1

4

3

2

1

4

3

2

1

4

3

2

1

4

3

2

1

4

3

2

1

4

3

2

1

4

3

2

1

4

3

2

1

4

3

2

1

4

3

2

1

4

3

2

1

4

3

2

1

4

3

2

1

4

3

2

1

4

3

2

1

4

3

2

1

4

3

2

1

4

3

2

1

4

3

2

1

4

3

2

1

4

3

2

1

4

3

2

1

4

3

2

1

4

3

2

1

4

3

2

1

4

3

2

1

4

3

2

1

4

3

2

1

4

3

2

1

4

3

2

1

4

3

2

1

4

3

2

1

4

3

2

1

4

3

2

1

4

3

2

1

4

3

2

1

4

3

2

1

4

3

2

1

4

3

2

1

4

3

2

1

4

3

2

1

4

3

2

1

4

3

2

1

4

3

2

1

4

3

2

1

4

3

2

1

4

3

2

1

4

3

2

1

4

3

2

1

4

3

2

1

4

3

2

1

4

3

2

1

4

3

2

1

4

3

2

1

4

3

2

1

4

3

2

1

4

3

2

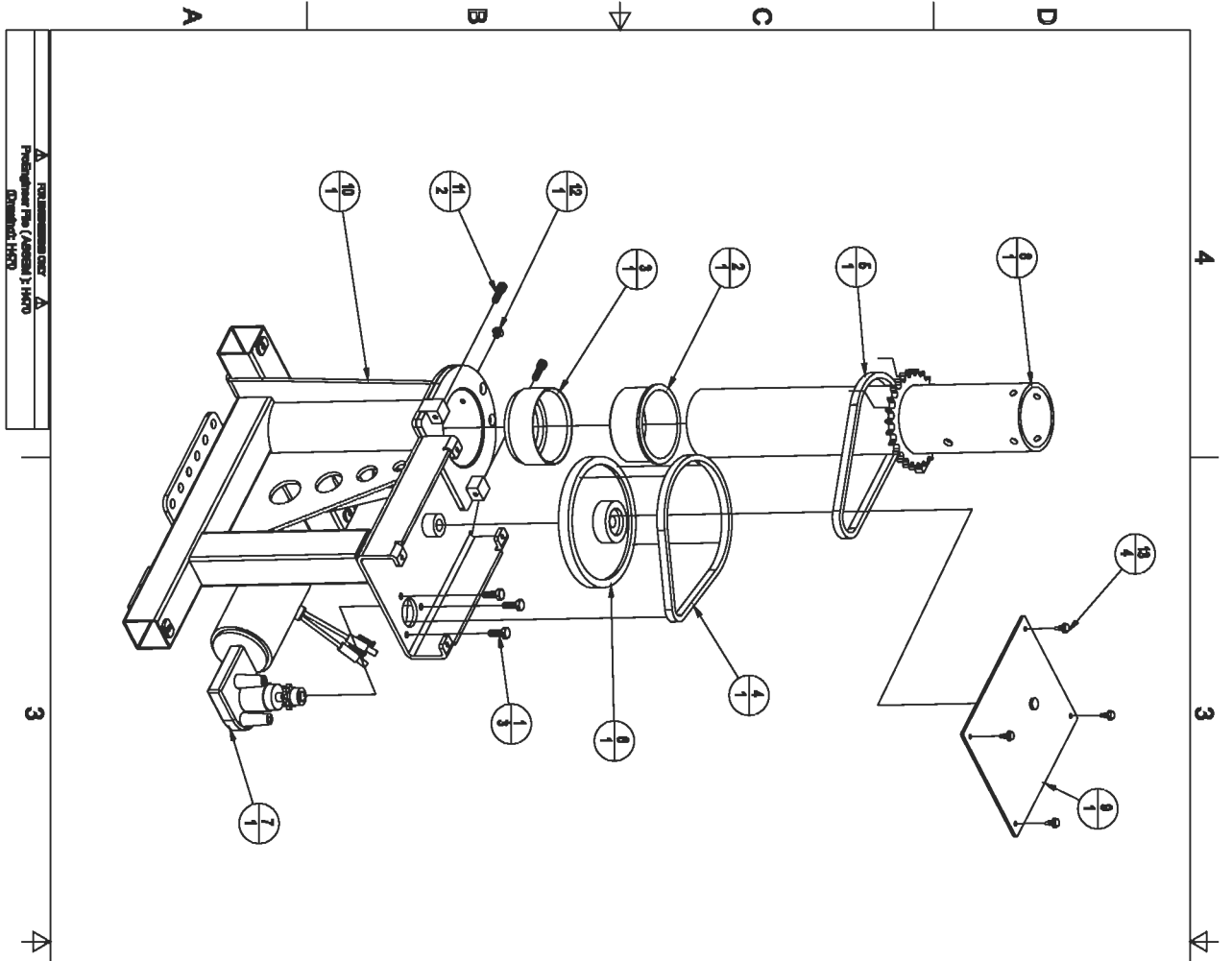

ITEM QTY	PART NO.	DESCRIPTION
1	JHCS	1/4-20 x 3/4" JHCS
2	AL420M	FLANGE BUSHING
3	AL4200S	CLIP BUSHING
4	AL4A021	36 PITCH CHAIN, 62 LINKS
5	AL4A022	40 PITCH CHAIN, 30 LINKS
6	AL4A04	DOUBLE SPRING
7	AL4A1011	ROTATION MOTOR
8	HA40	OUTER POST TUBE
9	HA40	BASE LID ASSY
10	HA70	WELDED BASE
11	HA70S	SHCS 1/4-20 x 3/4" 3000K
12	HA8S	1/4-20 x 28" NYLON Flat Head Round
13	4	TEX SCREW #12 x 1/2" self drilling

COMMERCIAL INFORMATION NOT TO BE COPIED OR REPRODUCED WITHOUT WRITTEN CONSENT FROM THE MANUFACTURER		DRAWING NO. H470	
TITLE AND QUANTITY ASSIGNED TO THIS DRAWING SHEET		IDENTIFICATION	
DESIGNED BY CHECKED BY APPROVED BY	DATE DATE DATE	FULLY POWERED BASE ASSEMBLY	
MATERIAL FINISH		DRAWN BY	DATE
SCALE 1:50		SHEET #	SHEETS OF 2



A FULLY POWERED BASE ASSEMBLY
 Prototype Part (Assess) : HA70
 Drawing: HA70

FOR INFORMATION ONLY
 Prototype Part (Assembled) H480
 Drawing: H480

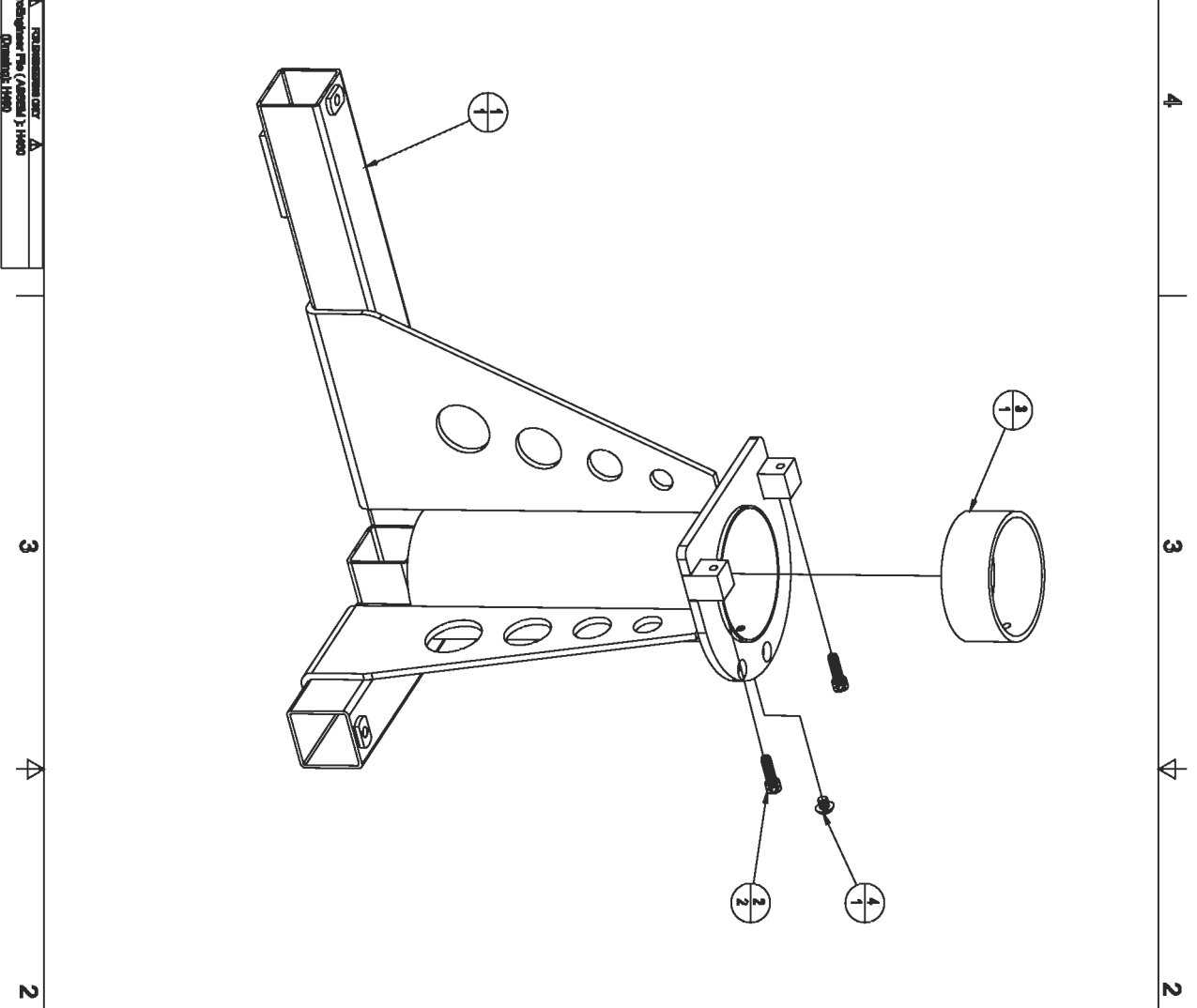

ASSEMBLY PARTS		
ITEM QTY	PART NO.	DESCRIPTION
1	H480	AL410 BASE (weld only)
2	HR7085	8X103 1/4-20 x 3/4" plate
3	HR7088	AL410 BRONZE BUSHING
4	HR855	1/4-20 x .25" NYLON FIBER Head Round

CONSTRUCTION INFORMATION PARTS TO BE ASSEMBLED WITHOUT FURTHER COMMENT UNLESS OTHERWISE SPECIFIED TOLERANCES ARE: DIMENSIONS: .005 HOLE DIA: .001 ANGLES: .01° UNLESS OTHERWISE SPECIFIED DO NOT SCALE DIMENSIONS		DRAWING NO. H480
DESCRIPTION AL410 BASE ASSEMBLY		DATE
MATERIAL	FINISH	DESIGNED BY
SCALE: 1:1	SIZE: B	DATE: 1-1-2



FOR INFORMATION ONLY
 Prototype Part (Assembled) H480
 Drawing: H480

Δ FOR ASSEMBLY ONLY Δ
 Procter & Gamble
 Cincinnati, OH 45202

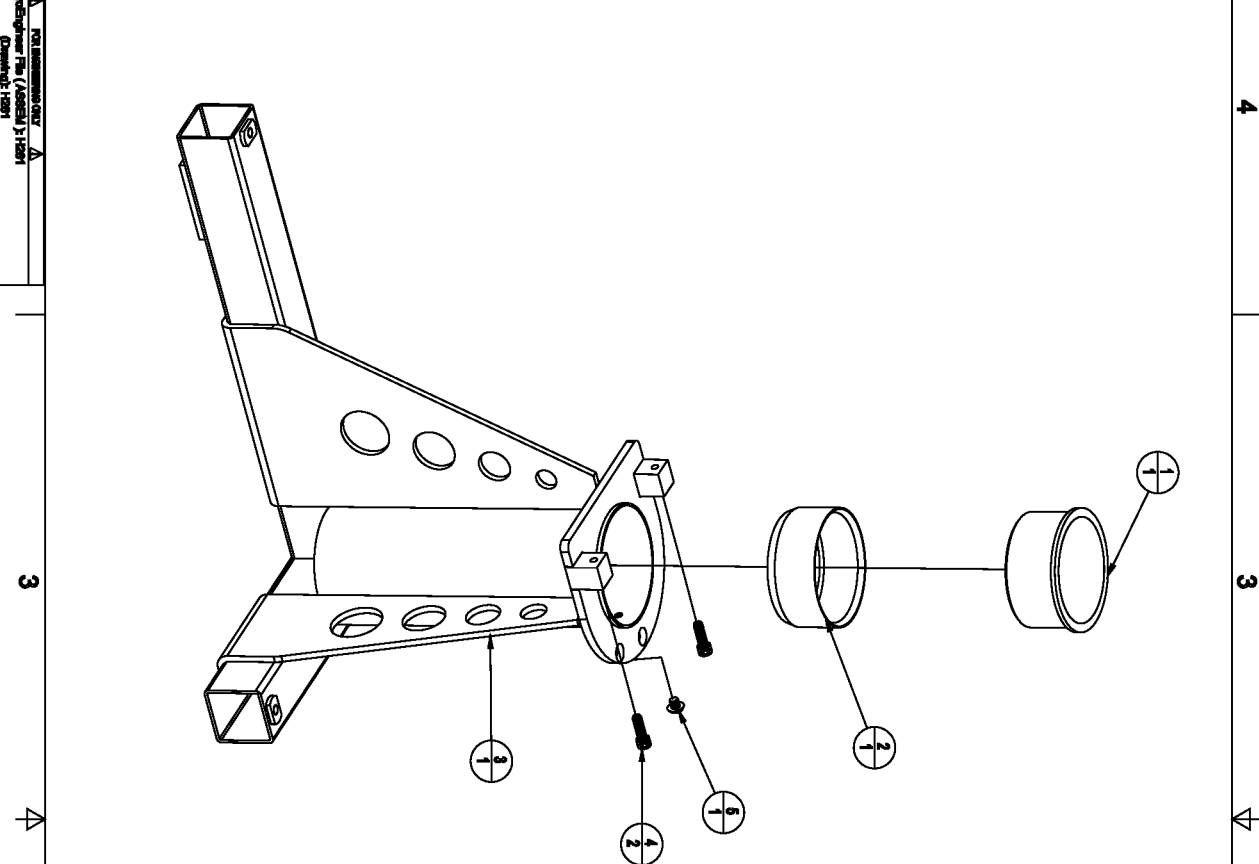

ASSEMBLY PARTS		
ITEM QTY	PART NO.	DESCRIPTION
1 1	AL2004	FLANGE BUSHING
2 1	AL2006	CLIP BUSHING
3 1	H2800	AL210 BASE (used only)
4 2	H4706	8XCS 1/4-20 x 3/4" plate
6 1	H955	1/4-20 x 2 1/2" NYLON FIM Head Round

CONCENTRIC ALIGNMENT DIMENSIONS SHOWN WITHOUT WRITTEN COMMENT		DIM NO. H261	
UNLESS OTHERWISE SPECIFIED TOLERANCES ARE: DIMENSIONS X.X .1 DIMENSIONS X.XX .05 DIMENSIONS X.XXX .01 ANGLES .5		DESCRIPTION AL210 BASE	
DO NOT SCALE DRAWING		MATERIAL FINISH DRAWN BY DATE	
		SIZE B SHEET 2 OF 2	

Δ FOR ASSEMBLY ONLY Δ
 Procter & Gamble
 Cincinnati, OH 45202

